



**EAOM-210 FD
AUTOMATIC TRANSFER & SWITCHING UNIT
FOR DIESEL/GAS GENERATORS
User Manual**

EMKO ELEKTRONIK A.S.
Demirtas Org. San. Bolg.
Karanfil Sk. No: 6 TR
16369 Bursa / TURKEY

Phone : +90 224 261 1900
Fax : +90 224 261 1912
Url : www.emkoelektronik.com.tr
e-mail : emko@emkoelektronik.com.tr
exposales@emkoelektronik.com.tr

Section 1 Introduction	4
Section 2 Installation	6
2.1 Unit Configuration	6
2.2 Mechanical Installation	6
Figure 2.3 Side view.....	7
2.3 Electrical Connections	7
Figure 2.4 Rear view.....	7
Figure 2.5 EAOM-210 FD three phase connections schematic.....	9
Table 2.1 Unit wiring.....	11
Table 2.2 Unit wiring description.....	13
Section 3 Definition Of Front Panel And Programming	15
3.1 Front Panel Description	15
3.2 Programming Procedure	17
3.3 Accessing to the Operator Parameters	17
3.3.1 Changing and Saving Operator Parameter Values.....	19
3.4 Accessing to the Technician Parameters	21
3.4.1 Changing and Saving Technician Parameter Values	27
3.5 Programmable function definitions	29
3.6 Pc Interface	66
3.6.1 Technical Specifications.....	66
3.6.2 RS-232 Serial Interface, Programming The Device Over PC or Modem	66
3.6.2.1 Cable Connection Between RS-232 Terminal of the Device and PC	66
3.6.2.2 Cable Connection Between RS-232 Terminal of the Device and Modem	66
3.6.3 Installation Instruction	66
3.6.3.1 Minimum system requirements	66
3.6.3.2 Installing EAOM-210 FD V02/SW.....	66
3.6.3.3 To Run EAOM-210 FD V02/SW communication software.....	67
3.6.4 Description	69
3.6.4.1 Main Menu.....	69
File Menu.....	69
Window Menu	69
Program Menu	70
Observation Menu.....	71
Operator Parameters Menu.....	75
Technician Parameters Menu	76
Adjusment Page (Calibration) Menu.....	77
Setting Menu.....	78
Help Menu.....	78
Section 4 Commissioning	79
4.1 Manual operation	79
4.2 Auto Operation	80
4.3 Test Mode Operation	80

Section 5 Operation	81
5.1 Controls and Indicators	81
5.1.1 Alternate Display Description	81
5.1.2 Voltage Display Description.....	88
5.1.3 Current Display Description.....	90
5.1.4 Failure Indicators Description.....	93
5.2 Mode transition	94
5.3 Manual Start	94
5.4 Manual Stop	94
5.5 Auto Operation	94
5.6 Test Operation	95
5.6.1 Exercise Function	95
Section 6 Fault Finding	96
6.1 General	96
6.2 Error Messages	96
Table 6.1 Fault finding	98
Section 7 Specifications & Ratings	99
Section 8 Block Diagram.....	102
User Defined Parameter:.....	103
List-1:.....	103

Section 1 Introduction

The EAOM-210 FD provides for automatic transfer of a load from mains to generator in the event of a mains failure. Intended for unattended operation, it is able to detect failure of any phase of the mains and to start and switch over to a generator if the mains voltage goes outside pre-set limits. Both automatic and manual control is possible. A test mode is also available which allows the generator to be run without taking the load.

The unit monitors generator operation and gives warning of any faults that are detected. The unit monitors:

- Engine speed
- Engine Oil pressure
- Coolant temperature
- Fuel Level
- Battery voltage
- Charge generator voltage
- Engine run time
- Number of starts
- Next maintenance
- Mains volts (L1-N, L2-N, L3-N)
- Mains volts (L1-L2, L2-L3, L3-L1)
- Mains Hz
- Generator volts (L1-N, L2-N, L3-N)
- Generator volts (L1-L2, L2-L3, L3-L1)
- Generator Hz
- Generator kVA
- Generator kW
- Generator kVAr
- Generator pf
- Generator kVAh
- Generator kWh
- Generator kVArh
- Load Amps
- Earth current (IEA)

It controls:

- Engine fuel supply or engine stopping
- Starter motor
- Alarm horn
- Automatic generator start and load transfer on mains failure
- Mains Open, Mains Close, Generator Open and Generator Close contactors

EAOM-210 FD features three-digit, seven-segment displays, including:

- Load Amps (IL1, IL2, IL3)
- Earth current (IEA)
- Generator kVAh
- Generator kWh
- Generator kVArh

-
- Generator pf

EAOM-210 FD features a three-digit, seven-segment display, including:

- Mains volts (L1-N, L2-N, L3-N)
- Mains volts (L1-L2, L2-L3, L3-L1)
- Generator volts (L1-N, L2-N, L3-N)
- Generator volts (L1-L2, L2-L3, L3-L1)

EAOM-210 FD features a four-digit, seven-segment display provides extensive monitoring of unit and generator parameters, including:

- Generator Hz
- Mains Hz
- Engine Rpm
- Generator kVA
- Generator kW
- Generator kVAr
- Engine Oil pressure
- Coolant temperature
- Fuel Level
- Battery voltage
- Charge generator voltage
- Real Time
- Engine run time
- Error messages (if available)
- Event messages
- Program parameters

The unit is extensively programmable through the front panel, with password protection on two levels. Operational parameters can also be monitored and controlled from a PC via a built-in RS232 port.

If the engine fails to start on the first attempt, further attempts are made up to a programmed number of times or until successful.

If a fault is detected, the unit shuts down the engine and indicates the failure by flashing a relevant fault LED.

Emergency stop input provide for remote control of the engine.

The user configurable inputs 1 and 2 can be programmed to perform 25 different functions. Other four user configurable inputs can be programmed to perform 24 different functions.

Four user configurable relay outputs can be programmed for 85 different functions.

Section 2 Installation



Please read the following information before installing.

A visual inspection of this product for possible damage occurred during shipment is recommended before installation. It is your responsibility to ensure that qualified mechanical and electrical technicians install this product.



Before beginning installation of this product:

- Disconnect all electrical power to the machine.
- Make sure the machine cannot operate during installation.
- Follow all safety warnings of the machine manufacturer.
- Read and follow all installation instructions.

2.1 Unit Configuration

The unit can be programmed using the buttons and display on the front panel or EAOM-210 FD software. Refer to [Section 3 Definition Of Front Panel And Programming](#) for details.

2.2 Mechanical Installation

The unit is designed for panel mounting. Fixing is by four screw fixings. (See Figure 2.1)

1. Insert the unit in the panel cut-out from the front.
2. Insert the fixings in the slotted at the corners of the unit and tighten the fixing screws to secure the unit against the panel.



During the equipment is putted in hole on the metal panel while mechanical installation some metal burrs can cause injury on hands, you should be careful. Installation parts of equipment should be tighten properly. The equipment can be drop from mounting place reason of vibration if installation parts leave soft.

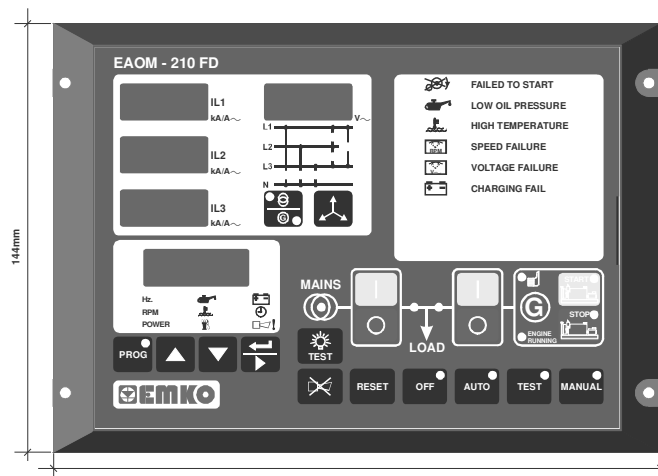

Figure 2.1 Front view.



Figure 2.2 Panel cut-out

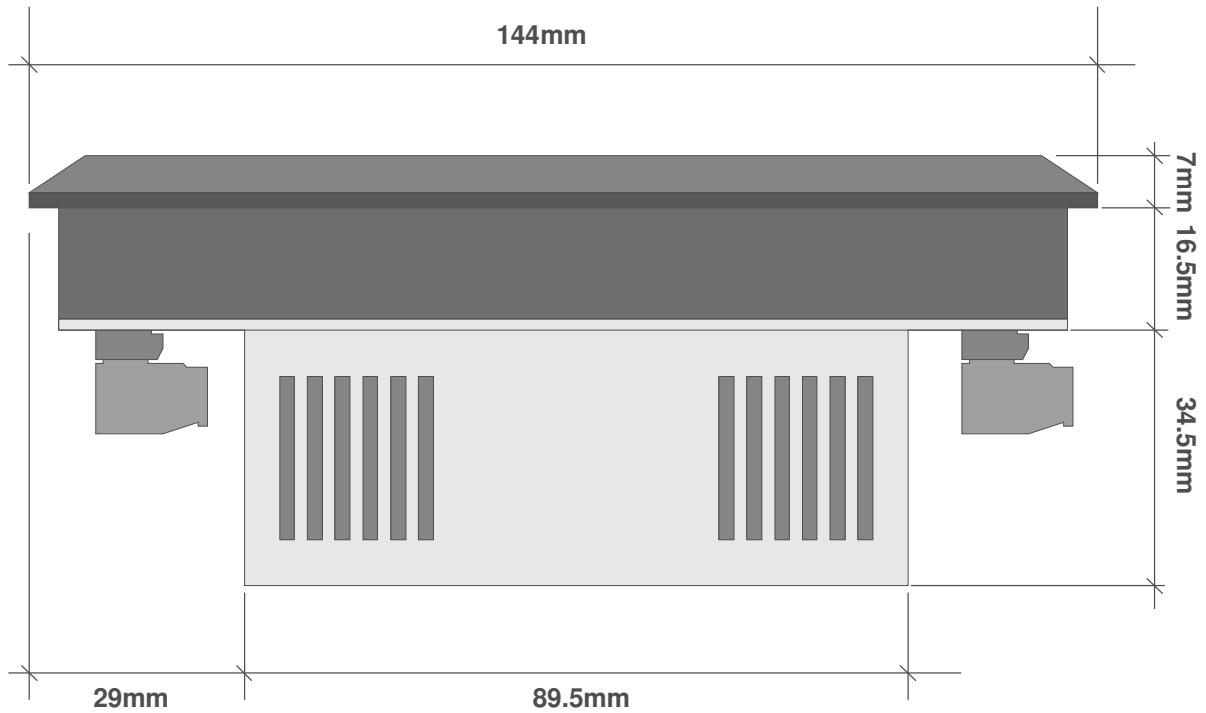

Figure 2.3 Side view.

2.3 Electrical Connections

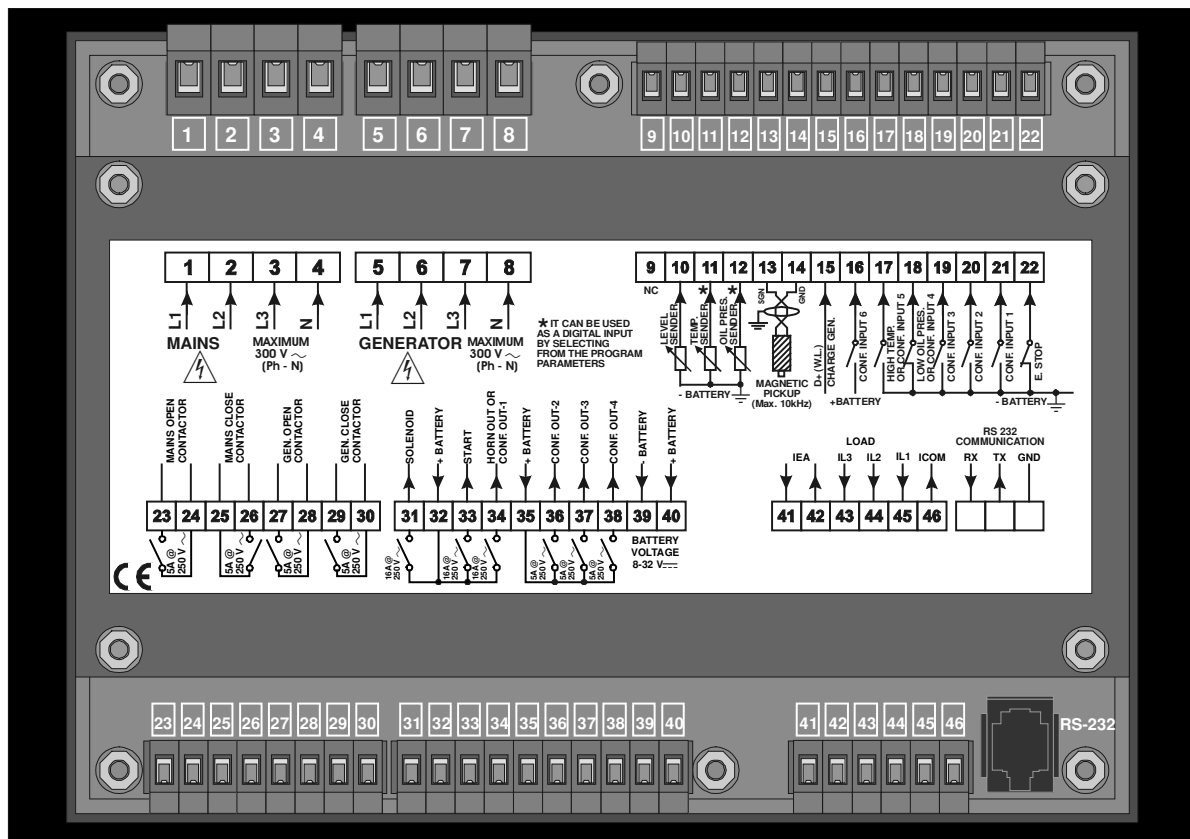

Figure 2.4 Rear view.



This equipment does not contain any parts and material related to users. Only qualified personnel and technician trained specially should work on this equipment. This equipment contains dangerous voltage inner circuits for human life . There is severe dangerous for human life on the case of unauthorised intervene.

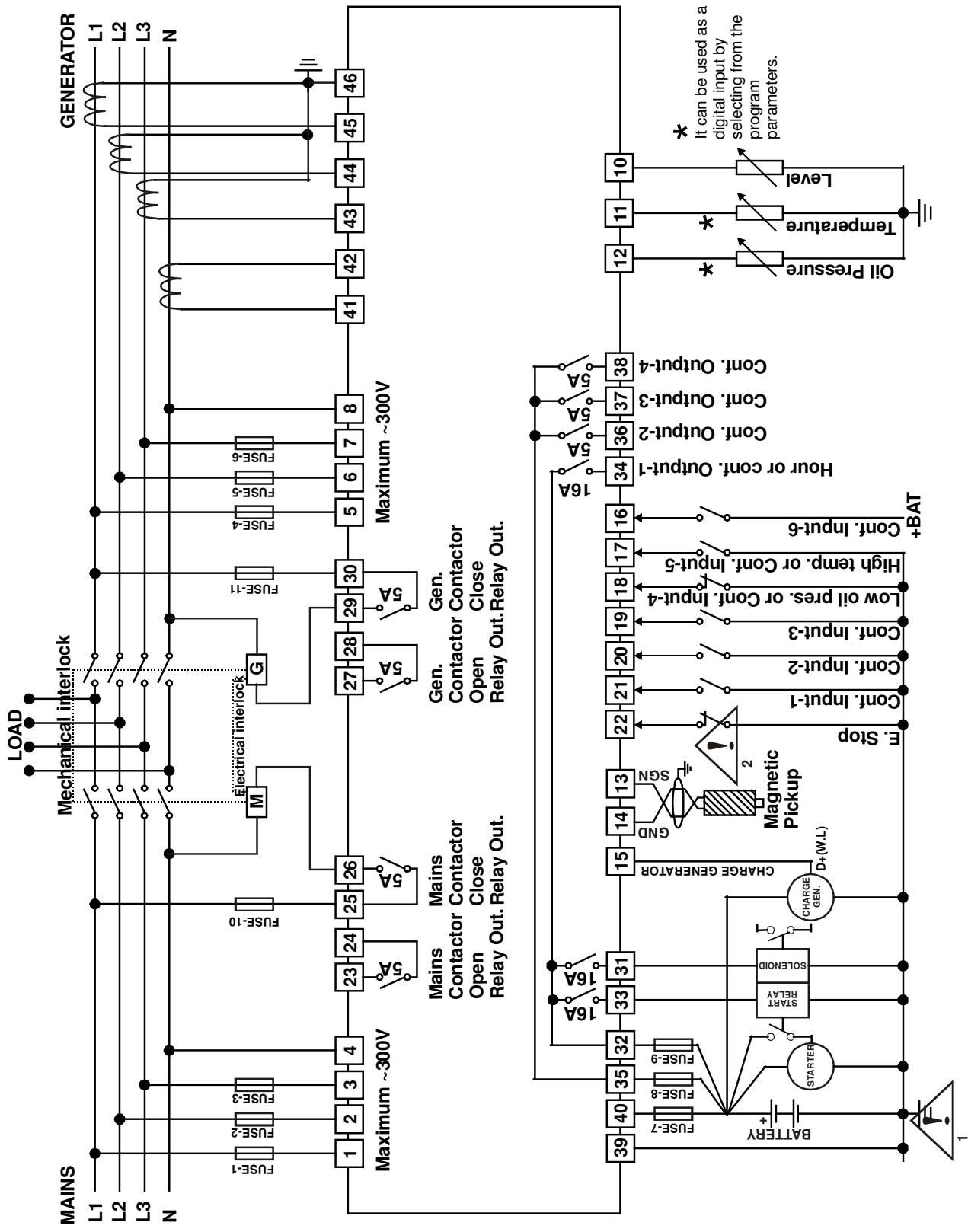



Figure 2.5 EAOM-210 FD three phase connections schematic.

FUSE-1, FUSE-2, FUSE-3, FUSE-4, FUSE-5, FUSE-6, FUSE-7 1 A. T

FUSE-8 should meet the current required by configurable output-2, 3, 4 - Max. 15 A. T

FUSE-9 should meet the current required by outputs Max. 16 A. T

FUSE-10, FUSE-11 Max. 5A. T

1-  Connect the unit as shown in the appropriate diagram, Figure 2.5 . Be sure to connect the battery supply the right way round and battery negative should be grounded. The connectors can be unplugged from the rear of the unit to facilitate connection.

2-  Screened cable must be used for connecting the Magnetic Pickup, ensuring that the screen is grounded at one end ONLY.

Table 2.1 shows the connections and recommended cable sizes. Table 2.2 describes the functions of the connections.

Table 2.1 Unit wiring

Pin	Description	Cable Size (mm ²)	Notes
1	Mains voltage input (L1)	2,5	
2	Mains voltage input (L2)	2,5	3 phase applications only.
3	Mains voltage input (L3)	2,5	3 phase applications only.
4	Mains voltage neutral	2,5	
5	Alternator voltage input (L1)	2,5	
6	Alternator voltage input (L2)	2,5	3 phase applications only.
7	Alternator voltage input (L3)	2,5	3 phase applications only.
8	Alternator voltage neutral	2,5	
9	Sender common	1	Connect to sender common
10	Fuel level sender	1	Connect to fuel level sender
11	Coolant temperature sender	1	Connect to Coolant temperature sender
12	Low oil pressure sender	1	Connect to Low oil pressure sender
13	Input from magnetic pick-up	1	Connect to magnetic pick-up device
14			
15	Input from charge generator	1	NC to "0" volt.
16	Configurable input-6	1	Switch to "BATTERY +".
17	High temperature or configurable input -5	1	Switch to "0" volt.
18	Low oil pressure or configurable input -4	1	Switch to "0" volt.
19	Configurable input-3	1	Switch to "0" volt.
20	Configurable input-2	1	Switch to "0" volt.
21	Configurable input-1	1	Switch to "0" volt.
22	Input from emergency stop	1	NC to "0" volt. When the switch is opened, the engine is stopped.
23	Mains Contactor Open Relay Output	2,5	
24	Mains Contactor Open Relay Output	2,5	
25	Mains Contactor Close Relay Output	2,5	
26	Mains Contactor Close Relay Output	2,5	
27	Gen. Contactor Open Relay Output	2,5	
28	Gen. Contactor Open Relay Output	2,5	
29	Gen. Contactor Close Relay Output	2,5	
30	Gen. Contactor Close Relay Output	2,5	
31	Output to fuel / stop solenoid	2,5	16 A. Max. DC supply from Pin 32
32	+Battery supply input	2,5	Supplies to Pin 31,33,34
33	Output to start	2,5	16 A. Max. DC supply from Pin 32
34	Horn or configurable relay output-1	2,5	16 A. Max. DC supply from Pin 32
35	+Battery supply input	2,5	Supplies to Pin 36,37,38

36	Configurable relay output-2	2,5	5 A. Max. DC supply from Pin 35
37	Configurable relay output-3	2,5	5 A. Max. DC supply from Pin 35
38	Configurable relay output-4	2,5	5 A. Max. DC supply from Pin 35
39	- Battery supply to EAOM-210 FD	2,5	Supplies to unit
40	+ Battery supply to EAOM-210 FD	2,5	Supplies to unit
41	CT Secondary for Earth current	2,5	Connect to secondary of Earth current monitoring CT
42	CT Secondary for Earth current	2,5	Connect to secondary of Earth current monitoring CT
43	CT Secondary for load L3	2,5	Connect to secondary of load L3 monitoring CT
44	CT Secondary for load L2	2,5	Connect to secondary of load L2 monitoring CT
45	CT Secondary for load L1	2,5	Connect to secondary of load L1 monitoring CT
46	CT Secondary for load common	2,5	Connect to secondary of load common monitoring CT

Table 2.2 Unit wiring description

Pin	Function	
1	L1	Mains voltage inputs. Used to detect failure for controlling automatic transfer of load to alternator. Pins 2 and 3 not used on single phase applications.
2	L2	
3	L3	
4	Mains voltage neutral	
5	L1	Alternator voltage inputs. Unit can be programmed to use frequency of alternator output to detect when engine has started. Pins 6 and 7 not used on single phase applications.
6	L2	
7	L3	
8	Alternator voltage neutral	
9	Sender common	
10	Fuel level sender	
11	Coolant temperature sender	
12	Low oil pressure sender	
13	Magnetic input +ve. An AC signal from the magnetic pick-up +ve for speed sensing.	
14	Magnetic input -ve. An AC signal from the magnetic pick-up -ve for speed sensing.	
15	Input from charge generator. Can be used to detect when engine has started.	
16	Configurable input-6. This is a negative switched configurable input, see Digital Configurable Input-6 Page Section for options available. It is possible to configure input to be a normally closed signal or a normally open signal.	
17	High Temperature or Configurable input-5. This is a negative switched. If Configurable input-5 is not selected as High Temperature, It is possible to configure input to be a normally closed signal or a normally open signal. See Digital Configurable Input-5 Page Section for options available.	
18	Low Oil Pressure or Configurable input-4. Normally closed contact. Switch to 0V. If Configurable input-4 is not selected as Low Oil Pressure, It is possible to configure input to be a normally closed signal or a normally open signal. See Digital Configurable Input-4 Page Section for options available.	
19	Configurable input-3. This is a negative switched configurable input, see Digital Configurable Input-3 Page Section for options available. It is possible to configure input to be a normally closed signal or a normally open signal.	
20	Configurable input-2. This is a negative switched configurable input, see Digital Configurable Input-2 Page Section for options available. It is possible to configure input to be a normally closed signal or a normally open signal.	
21	Configurable input-1. This is a negative switched configurable input, see Digital Configurable Input-1 Page Section for options available. It is possible to configure input to be a normally closed signal or a normally open signal.	
22	Input from emergency stop switch. Normally closed contact. Switch to 0V. when the switch is opened, the engine is stopped.	
23	Mains Contactor Open Relay Output. See Breakers Page Section for options available. Volts free contacts to 24.	
24	Mains Contactor Open Relay Output. See Breakers Page Section for options available. Volts free contacts to 24.	
25	Mains Contactor Close Relay Output. See Breakers Page Section for options available. Volts free contacts to 26.	
26	Mains Contactor Close Relay Output. See Breakers Page Section for options available. Volts free contacts to 25.	
27	Gen. Contactor Open Relay Output. See Breakers Page Section for options available. Volts free contacts to 28.	

28	Gen. Contactor Open Relay Output. See Breakers Page Section for options available. Volts free contacts to 27.
29	Gen. Contactor Close Relay Output. See Breakers Page Section for options available. Volts free contacts to 30.
30	Gen. Contactor Close Relay Output. See Breakers Page Section for options available. Volts free contacts to 29.
31	Output to fuel / stop relay. DC supply from Pin 32. Controls fuel to engine or controls engine stopping.
32	+Battery supply input. Supplies to Pin 31,33,34
33	Output to start relay. DC supply from Pin 32. Controls starter motor.
34	Horn or configurable relay output-1. DC supply from Pin 32. See Configurable Output-1 Page Section for options available.
35	+Battery supply input. Supplies to Pin 36,37,38
36	Configurable relay output-2. DC supply from Pin 35. See Configurable Output-2 Page Section for options available.
37	Configurable relay output-3. DC supply from Pin 35. See Configurable Output-3 Page Section for options available.
38	Configurable relay output-4. DC supply from Pin 35. See Configurable Output-4 Page Section for options available.
39	- Battery input supplies EAOM-210 FD
40	+ Battery input supplies EAOM-210 FD
41	CT Secondary for Earth current (IEA).
42	CT Secondary for Earth current (IEA).
43	CT Secondary for load L3.
44	CT Secondary for load L2.
45	CT Secondary for load L1.
46	CT Secondary for load common.

Number	Comment:
19	This button closes the alternator contactor, only operative when manual mode is selected.
20	This button opens the alternator contactor, only operative when manual mode is selected.
21	The START button is used for starting the engine when the unit is in the Manual Mode.
22	The STOP button is used for stopping the engine when the unit is in the Manual Mode.
23	When this button is pressed, the unit goes into its PROGRAMMING Mode and LED (10) illuminates.
24	This button is used for showing kVAh, kWh, kVArh values. In Programming mode, it operates as an Increment function (increase value).
25	This button is used for showing kVAh, kWh, kVArh values. In Programming mode, it operates as an Decrement function (decrease value).
26	The Display Scroll Button is used for rotating between measurement screens in normal operation, and between programming parameters in programming mode.
27	The LAMP TEST button illuminates all LED indicators and display segments.
28	This button will silence the alarm horn after a failure has been detected.
29	This button will reset the controller after a failure has been detected.
30	The OFF button is used for changing operating mode of the unit to the OFF Mode.
31	The AUTO button is used for changing operating mode of the unit to the AUTO Mode.
32	The TEST button is used for changing operating mode of the unit to the TEST Mode.
33	The MAN button is used for changing operating mode of the unit to the MANUAL Mode.
34	Multi Function Display. This is used for displaying the electrical measurements during normal operation (features explained in section 5.1.1.), and editing/inspecting programming parameters in program mode.
35	Three digit, seven segment display. The display shows Load Amp IL1.
36	Three digit, seven segment display. The display shows Load Amp IL2.
37	Three digit, seven segment display. The display shows Load Amp IL3.
38	Three digit, seven segment display. The display shows Mains volts and Generator volts.
39	Failure Indicators. Detailed information available in section 5.1.2.

3.2 Programming Procedure

Many of the unit functions can be set by programming. Programming can be carried out only while the unit is in **OFF** mode. Press the OFF (30) button. If the engine is running, it will stop and the LED (11) lights on.

The parameters have been divided into groups according to their functions. Every group has a title and firstly user must determine the title (page) for accessing to the parameters. Refer to the parameters section for detailed information about parameters.

3.3 Accessing to the Operator Parameters

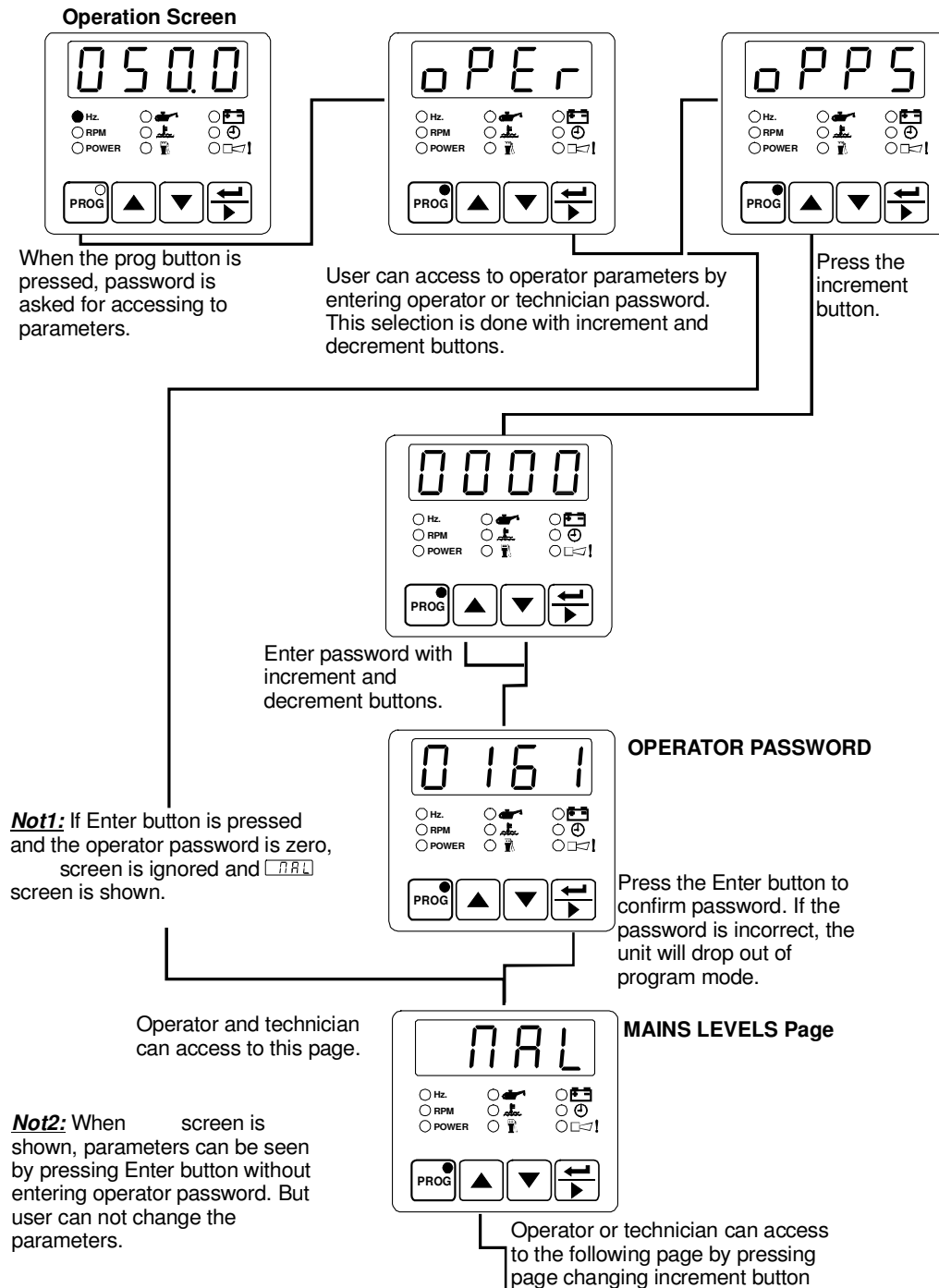

Operator and technician can access to this page

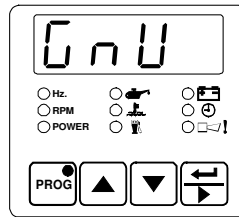

GENERATOR VOLTAGE LEVELS Page

Operator or technician can access to the following page by pressing page changing increment button

Operator or technician can access to the former page by pressing page changing decrement button.

Operator and technician can access to this page

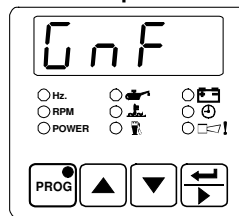

GENERATOR FEQUENCY LEVELS Page

If the sensing options generator frequency parameter(Gen1) in Miscellaneous page(Gen) is disable, this page is ignored.

Operator or technician can access to the following page by pressing page changing increment button

Operator or technician can access to the former page by pressing page changing decrement button.

Operator and technician can access to this page

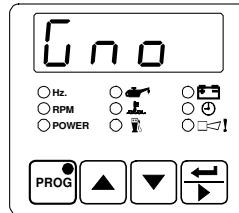

GENERATOR CURRENT/POWER LEVELS Page

Operator or technician can access to the former page by pressing page changing decrement button.

Press prog button to exit from Program Mode and turn to operation screen.

Continue to press page changing increment and decrement buttons to change the page.

By pressing ENTER button, user can access to all parameters in related page.

3.3.1 Changing and Saving Operator Parameter Values

Example-1 : To change Mains Under Voltage parameter in "MAL" page, user must access to "MAL" page firstly.

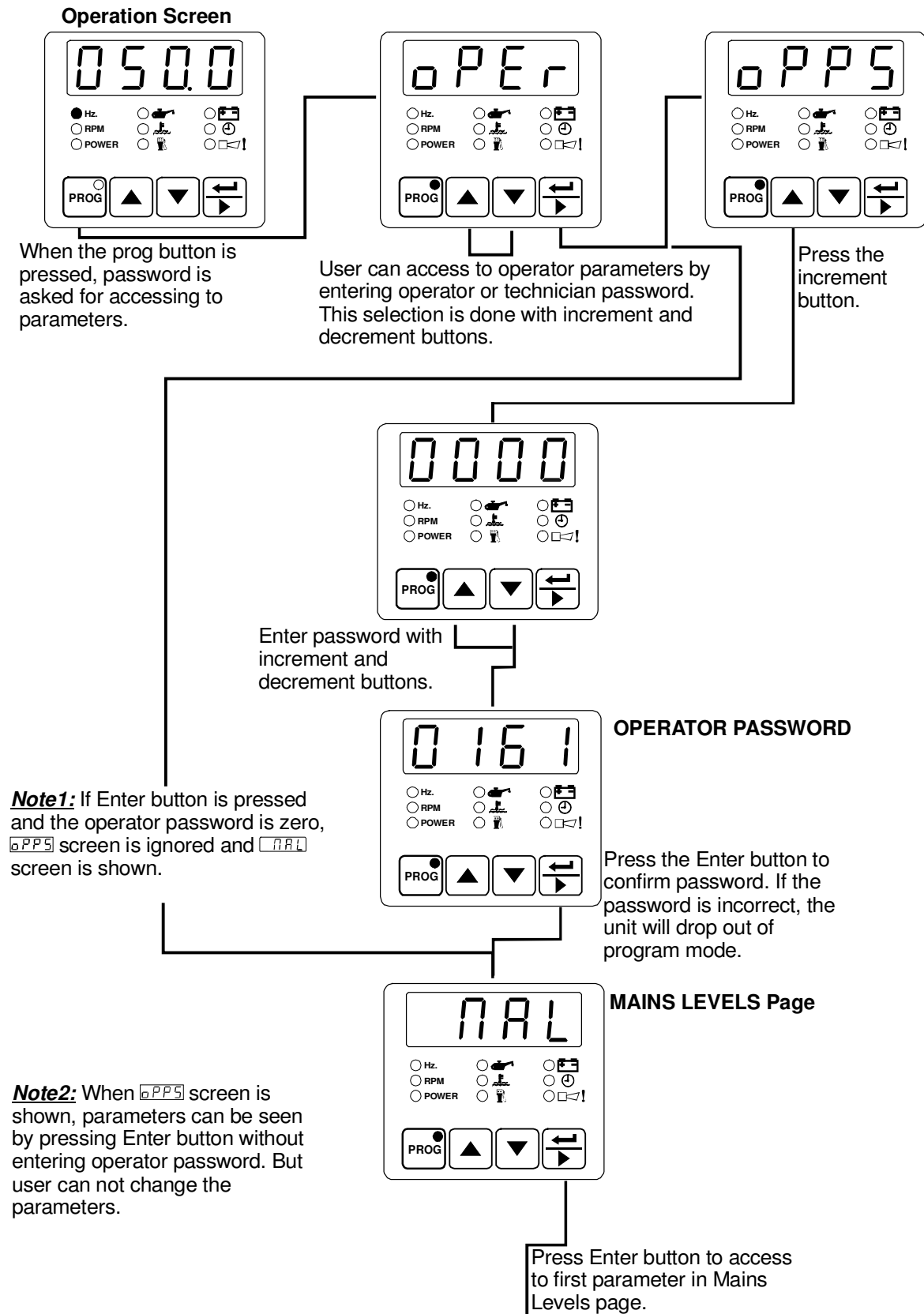

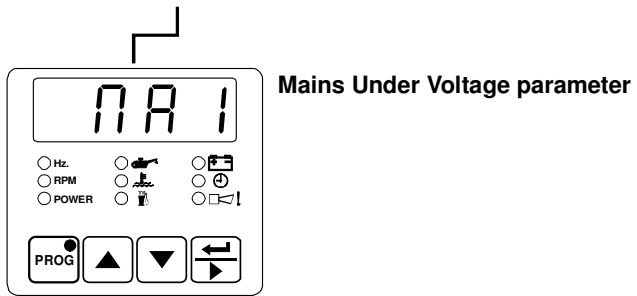

Press the increment button to access to the parameter value.

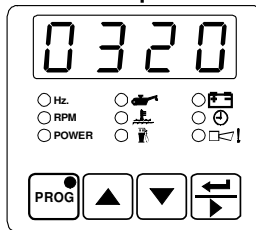

Parameter can be changed with increment and decrement buttons

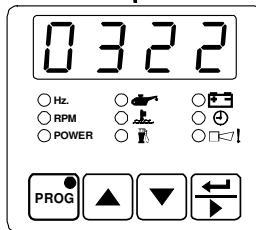

Press Enter button to confirm the changed value and access to the following parameter.

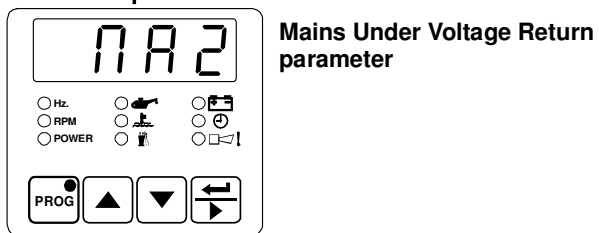

When Prog button is pressed, related page can be accessed.

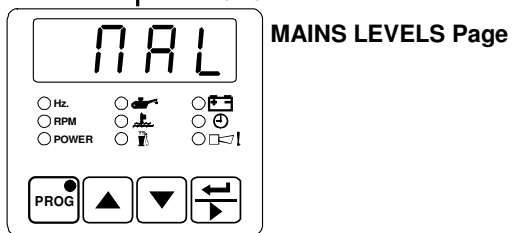

If Prog button is pressed again, operation screen is shown.

Continue to press PAGE changing increment and decrement buttons to change the page.

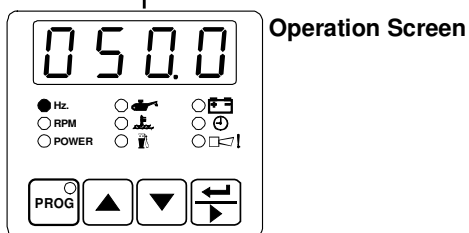

3.4 Accessing to the Technician Parameters

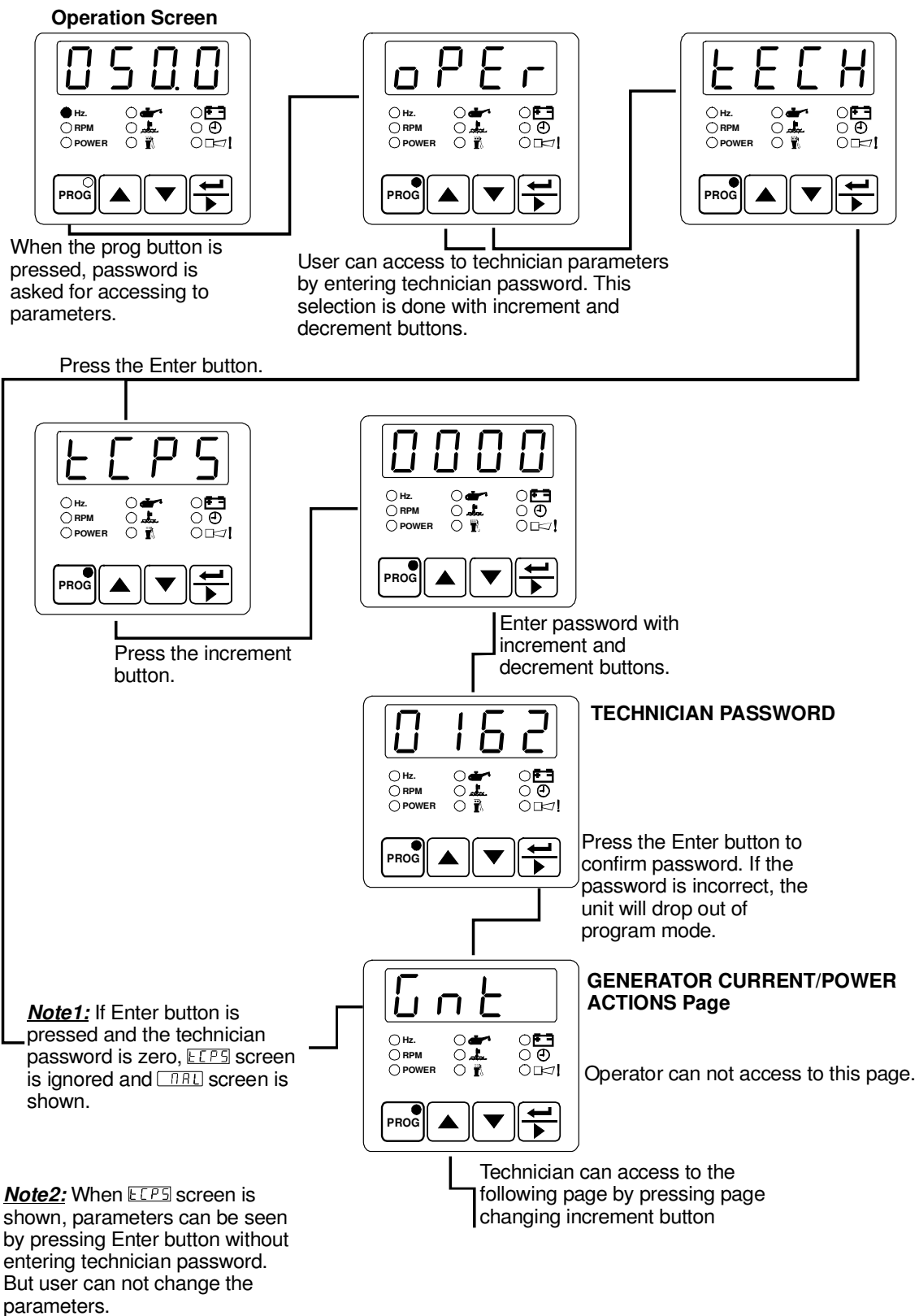

Operator can not access to this page.

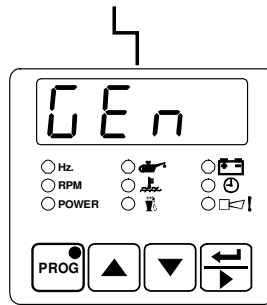

MISCELLANEOUS Page

Technician can access to the former page by pressing page changing decrement button.

Technician can access to the following page by pressing page changing increment button

Operator can not access to this page.

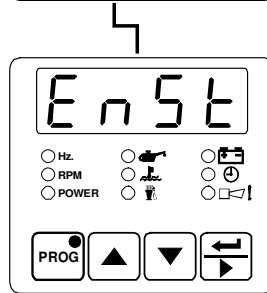

ENGINE STARTING OPTIONS Page

Technician can access to the former page by pressing page changing decrement button.

Technician can access to the following page by pressing page changing increment button

Operator can not access to this page.

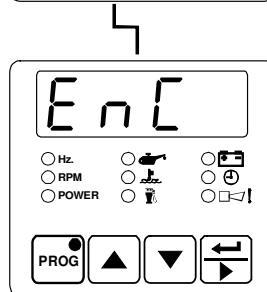

ENGINE CRANK DISCONNECT Page

Technician can access to the former page by pressing page changing decrement button.

Technician can access to the following page by pressing page changing increment button

Operator can not access to this page.

If the sensing options pick up parameter(Gen2) in Miscellaneous page(Gen) is disable, this page is ignored.

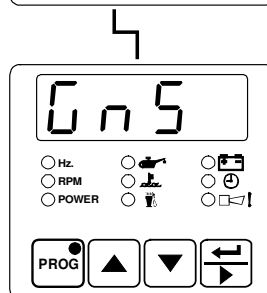

GENERATOR SPEED SETTINGS Page

Technician can access to the former page by pressing page changing decrement button.

Technician can access to the following page by pressing page changing increment button

Operator can not access to this page.

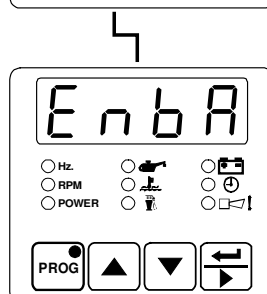

ENGINE PLANT BATTERY Page

Technician can access to the former page by pressing page changing decrement button.

Technician can access to the following page by pressing page changing increment button

Operator can not access to this page.

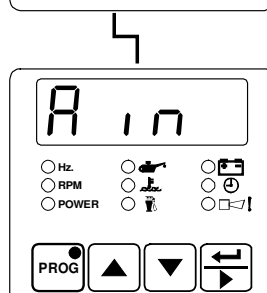

ANALOGUE INPUTS Page

Technician can access to the former page by pressing page changing decrement button.

Technician can access to the following page by pressing page changing increment button

Operator can not access to this page.

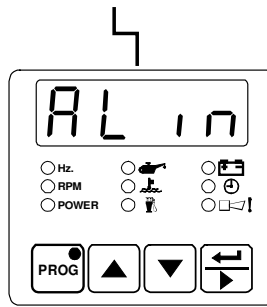

**ANALOGUE SENDER
LINEARISATIONS Page**

Technician can access to the former page by pressing page changing decrement button.

Technician can access to the following page by pressing page changing increment button

Operator can not access to this page.

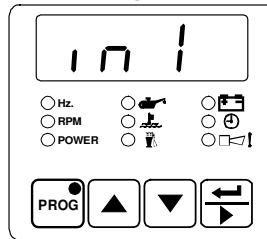

**DIGITAL CONFIGURABLE
INPUT-1 Page**

Technician can access to the former page by pressing page changing decrement button.

Technician can access to the following page by pressing page changing increment button

Operator can not access to this page.

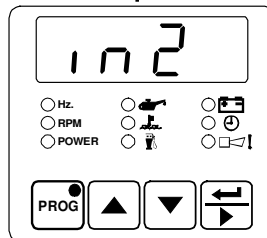

**DIGITAL CONFIGURABLE
INPUT-2 Page**

Technician can access to the former page by pressing page changing decrement button.

Technician can access to the following page by pressing page changing increment button

Operator can not access to this page.

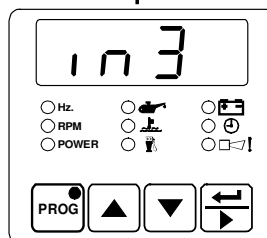

**DIGITAL CONFIGURABLE
INPUT-3 Page**

Technician can access to the former page by pressing page changing decrement button.

Technician can access to the following page by pressing page changing increment button

Operator can not access to this page.

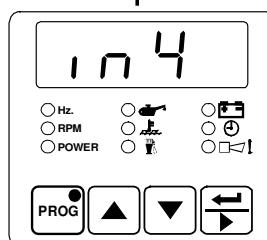

**DIGITAL CONFIGURABLE
INPUT-4 Page**

Technician can access to the former page by pressing page changing decrement button.

Technician can access to the following page by pressing page changing increment button

Operator can not access to this page.

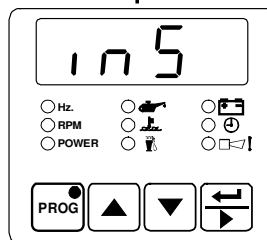

**DIGITAL CONFIGURABLE
INPUT-5 Page**

Technician can access to the former page by pressing page changing decrement button.

Technician can access to the following page by pressing page changing increment button

Operator can not access to this page.

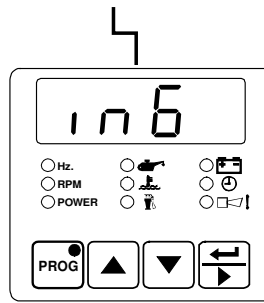

DIGITAL CONFIGURABLE INPUT-6 Page

Technician can access to the former page by pressing page changing decrement button.

Technician can access to the following page by pressing page changing increment button

Operator can not access to this page.

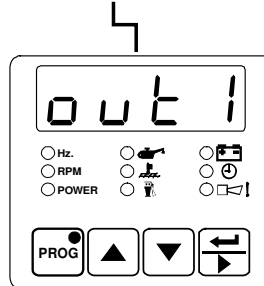

CONFIGURABLE OUTPUT-1 Page

Technician can access to the former page by pressing page changing decrement button.

Technician can access to the following page by pressing page changing increment button

Operator can not access to this page.

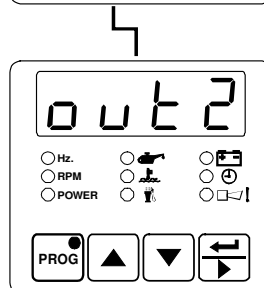

CONFIGURABLE OUTPUT-2 Page

Technician can access to the former page by pressing page changing decrement button.

Technician can access to the following page by pressing page changing increment button

Operator can not access to this page.

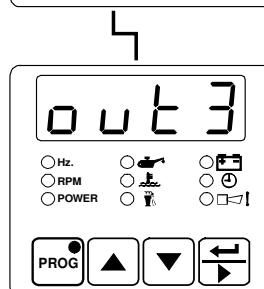

CONFIGURABLE OUTPUT-3 Page

Technician can access to the former page by pressing page changing decrement button.

Technician can access to the following page by pressing page changing increment button

Operator can not access to this page.

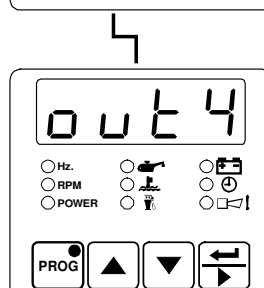

CONFIGURABLE OUTPUT-4 Page

Technician can access to the former page by pressing page changing decrement button.

Technician can access to the following page by pressing page changing increment button

Operator can not access to this page.

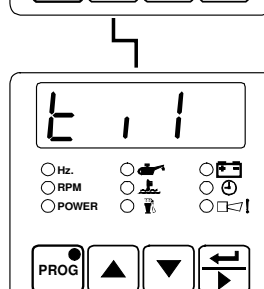

START TIMERS Page

Technician can access to the former page by pressing page changing decrement button.

Technician can access to the following page by pressing page changing increment button

Operator can not access to this page.

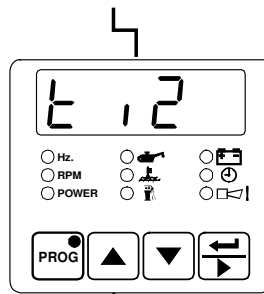

LOAD/STOPPING TIMERS Page

Technician can access to the former page by pressing page changing decrement button.

Technician can access to the following page by pressing page changing increment button

Operator can not access to this page.

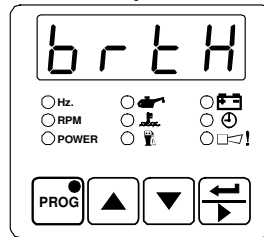

BREAKERS Page

Technician can access to the former page by pressing page changing decrement button.

Technician can access to the following page by pressing page changing increment button

Operator can not access to this page.

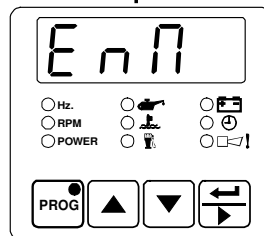

ENGINE MAIN TENANCE ALARM Page

Technician can access to the former page by pressing page changing decrement button.

Technician can access to the following page by pressing page changing increment button

Operator can not access to this page.

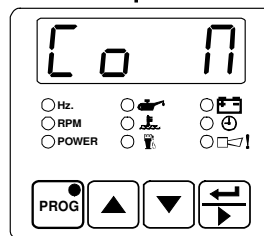

COMMUNICATION Page

Technician can access to the former page by pressing page changing decrement button.

Technician can access to the following page by pressing page changing increment button

Operator can not access to this page.

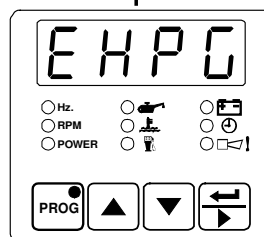

EXERCISE Page

Technician can access to the former page by pressing page changing decrement button.

Technician can access to the following page by pressing page changing increment button

Operator can not access to this page.

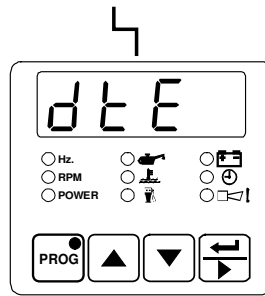

DATE Page

Technician can access to the following page by pressing page changing increment button

Technician can access to the former page by pressing page changing decrement button.

Operator can not access to this page.

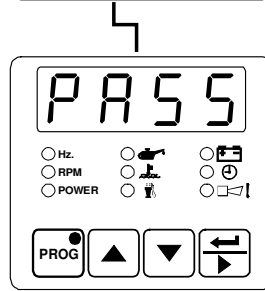

PASSWORD Page

Technician can access to the former page by pressing page changing decrement button.

Press prog button to exit from Program Mode and turn to operation screen.

Continue to press page changing increment and decrement buttons to change the page.

By pressing ENTER button, user can access to all parameters in related page.

3.4.1 Changing and Saving Technician Parameter Values

Example-1 : To change CT Primary parameter in "Gnt" page, user must access to "Gnt" page firstly.

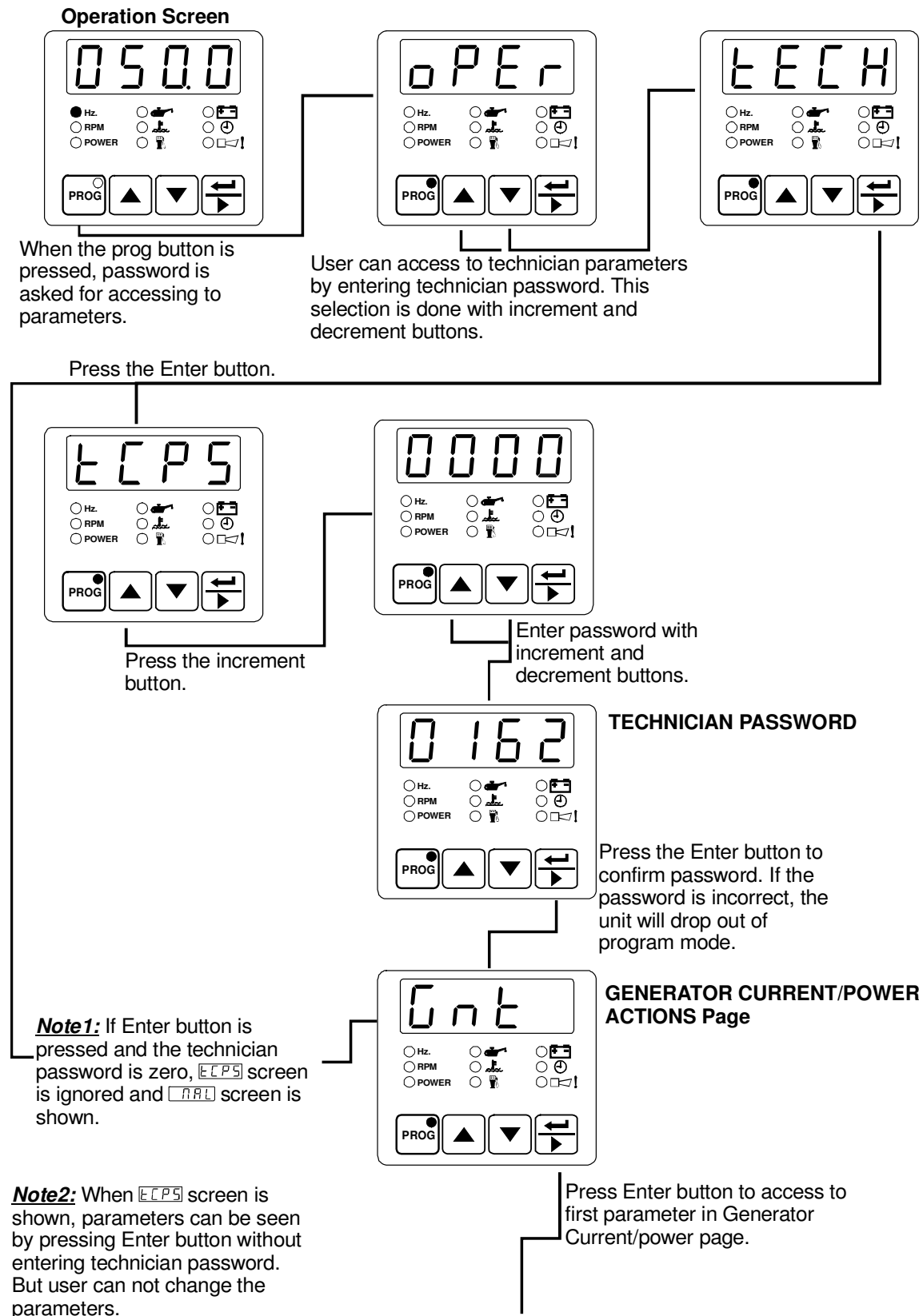

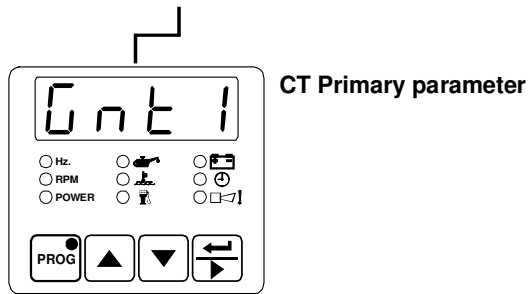

CT Primary parameter

Press the increment button to access to the parameter value.

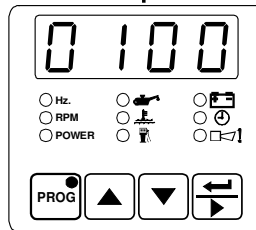

Parameter can be changed with increment and decrement buttons

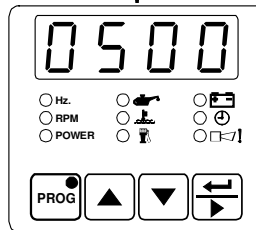

Press Enter button to confirm the changed value and access to the following parameter.

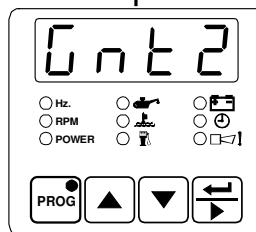

CT Primary (Earth Fault) parameter

When Prog button is pressed, related page can be accessed.

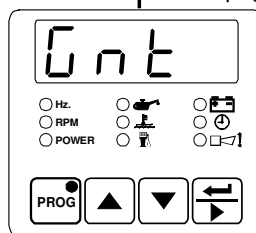

GENERATOR CURRENT/POWER ACTIONS Page

If Prog button is pressed again, operation screen is shown.

Continue to press PAGE changing increment and decrement buttons to change the page.

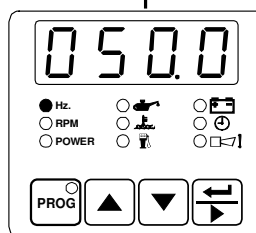

Operation Screen

3.5 Programmable function definitions

Operator parameters

(mAL) MAINS LEVELS page				
mA1	MAINS UNDER VOLTAGE	VAC	60 – 600	320
mA2	MAINS UNDER VOLTAGE RETURN	VAC	60 – 600	340
mA3	MAINS OVER VOLTAGE	VAC	60 – 600	440
mA4	MAINS OVER VOLTAGE RETURN	VAC	60 – 600	420
mA5	MAINS UNDER FREQUENCY	Hz	20.0 – 75.0	45.0
mA6	MAINS UNDER FREQUENCY RETURN	Hz	20.0 – 75.0	48.0
mA7	MAINS OVER FREQUENCY	Hz	20.0 – 75.0	55.0
mA8	MAINS OVER FREQUENCY RETURN	Hz	20.0 – 75.0	52.0

The unit uses these parameters to decide when to lit the “Mains Okey LED”.
In Automatic mode, the unit uses these parameters to switch the load between the mains supply and the alternator.

(GnU) GENERATOR VOLTAGE LEVELS page				
GnU1	GENERATOR UNDER VOLTAGE	VAC	(dis)60 – 600	320
GnU2	GENERATOR UNDER VOLTAGE PRE-ALARM	VAC	(dis)60 – 600	340
GnU3	GENERATOR LOADING VOLTAGE	VAC	60 – 600	345
GnU4	GENERATOR OVER VOLTAGE PRE-ALARM	VAC	(dis)60 – 600	420
GnU5	GENERATOR OVER VOLTAGE PRE-ALARM RETURN	VAC	60 – 600	400
GnU6	GENERATOR OVER VOLTAGE SHUTDOWN	VAC	60 – 600	440

The unit uses these parameters to decide when to display Voltage Failure and Voltage Error Messages. Also, the unit uses Generator Loading Voltage parameter to decide when to take the load.

(GnF) GENERATOR FREQUENCY LEVELS page				
GnF1	GENERATOR UNDER FREQUENCY	Hz	(dis)30.0 – 75.0	43.0
GnF2	GENERATOR UNDER FREQUENCY PRE-ALARM	Hz	(dis)30.0 – 75.0	45.0
GnF3	GENERATOR LOADING FREQUENCY	Hz	30.0 – 75.0	46.0
GnF4	GENERATOR OVER FREQUENCY PRE-ALARM	Hz	(dis)30.0 – 75.0	55.0
GnF5	GENERATOR OVER FRQ PRE-ALARM RETURN	Hz	30.0 – 75.0	54.0
GnF6	GENERATOR OVER FREQUENCY SHUTDOWN	Hz	(dis)30.0 – 75.0	58.0

The unit uses these parameters to decide when to display Speed Failure and Frequency Error Messages. Also, the unit uses Generator Loading Frequency parameter to decide when to take the load.

(Gno) GENERATOR CURRENT/POWER LEVELS page				
Gno1	GENERATOR OVER CURRENT	A AC	0 – 9999	9999
Gno2	GENERATOR SHORT CIRCUIT	A AC	0 – 9999	9999
Gno3	GENERATOR EARTH FAULT	A AC	0 – 9999	100
Gno4	MINIMUM ACTIVE POWER	kW	0 – 9999	50

Technician parameters

(Gnt) GENERATOR CURRENT/POWER ACTIONS page				
Gnt0	A / KA SELECTION (0 = Ampere, 1 = KiloAmpere)	-	0 – 1	0
Gnt1	CT PRIMARY	A AC	0 – 9999	500
Gnt2	CT PRIMARY (EARTH FAULT)	A AC	0 – 9999	500
Gnt3	OVER CURRENT ACTIONS -DISABLE -WARNING (ALARM ONLY, NO SHUTDOWN) -ELECTRICAL TRIP (ALARM/OFF LOAD GENERATOR FOLLOWED BY SHUTDOWN AFTER COOLING) -SHUTDOWN (ALARM AND SHUTDOWN)	-	0-3	dis
Gnt4	OVER CURRENT ALARM TIME	Sec	0 - 99	0
Gnt5	SHORT CIRCUIT ACTIONS -DISABLE -WARNING (ALARM ONLY, NO SHUTDOWN) -ELECTRICAL TRIP (ALARM/OFF LOAD GENERATOR FOLLOWED BY SHUTDOWN AFTER COOLING) -SHUTDOWN (ALARM AND SHUTDOWN)	-	0-3	dis
Gnt6	SHORT CIRCUIT ALARM TIME	Sec	0 - 99	0
Gnt7	EARTH FAULT ACTIONS -DISABLE -WARNING (ALARM ONLY, NO SHUTDOWN) -ELECTRICAL TRIP (ALARM/OFF LOAD GENERATOR FOLLOWED BY SHUTDOWN AFTER COOLING) -SHUTDOWN (ALARM AND SHUTDOWN)	-	0-3	dis
Gnt8	EARTH FAULT ALARM TIME	Sec	0 - 99	0
Gnt9	REVERSE POWER ACTIONS -DISABLE -WARNING (ALARM ONLY, NO SHUTDOWN) -ELECTRICAL TRIP (ALARM/OFF LOAD GENERATOR FOLLOWED BY SHUTDOWN AFTER COOLING) -SHUTDOWN (ALARM AND SHUTDOWN)	-	0-3	dis
Gnt10	REVERSE POWER ALARM TIME	Sec	0 - 99	0
Gnt11	TOTAL ENERGY CLEAR	-	No-YES	no
Gnt12	ACTIVE ENERGY CLEAR	-	No-YES	no
Gnt13	REACTIVE ENERGY CLEAR	-	No-YES	no

(GEn) MISCELLANEOUS page				
Gen1	SENSING OPTIONS GENERATOR FRQ EN/DIS	-	ENAB DIS	ENAB
Gen2	SENSING OPT PICKUP EN/DIS & FLYWHEEL	-	(dis)0-1000	DIS
Gen3	AC SYSTEM: 0= 1PHASE 2WIRE 1= 3PHASE 4WIRE 2= 3PHASE 4WIRE SERIES DELTA 3= 1PHASE 3WIRE	-	0-3	1
Gen4	FAST LOADING FEATURE EN/DIS	-	ENAB DIS	DIS
Gen5	ALL WARNINGS ARE LATCHED EN/DIS	-	ENAB DIS	DIS
Gen6	MAINS FAILURE DETECTION EN/DIS	-	ENAB DIS	ENAB
Gen7	LOOK MAINS FAILURE FOR MAINS CONT. EN/DIS	-	ENAB DIS	DIS
Gen8	ENGINE FUEL (GAS/ DIESEL) SELECTION	-	GAS/ DIESEL	DIESEL
Gen9	STOP / FUEL SELECTION	-	STOP/FUEL	FUEL
Ge10	STOP SOLENOID TIME	Sec	5 - 99	20
Ge11	IGNITION DELAY	Sec	1 - 99	5
Ge12	GAS VALVE DELAY	Sec	1 - 99	5
Ge13	MIN IGNITION SPEED	RPM	10 - 1500	200

SENSING OPTIONS GENERATOR FRQ EN/DIS:

ENABLE: Speed sensing will be derived from the generator output frequency.

DISABLE: Speed sensing not will be derived from the generator output frequency.

SENSING OPT. PICKUP EN/DIS & FLYWHEEL

DISABLE: Speed sensing will not be derived from the magnetic pickup.

1-1000: Speed sensing will be derived from the magnetic pickup and the number is flywheel teeth on the engine.

AC SYSTEM 3 PHASE 4 WIRE OR 1 PHASE 2 WIRE

0: AC system is 1 phase 2 wire.

1: AC system is 3 phase 4 wire.

2: AC system is 3 phase 4 wire series delta.

3: AC system is 1 phase 3 wire.

FAST LOADING FEATURE EN/DIS

ENABLE: The module will terminate the safety on timer once all monitored parameters have reached their normal settings. This feature is useful if the module is to be used as a standby controller as it allows the generator to start and go on load in the shortest possible time.

DISABLE: Normal operation, the safety on timer will be observed in full. This feature is useful if the module is to be used with some small engines where pre-mature termination of the delay timer can lead to overspeed alarms on start up.

ALL WARNINGS ARE LATCHED EN/DIS

Disable: Normal operation, the warnings and pre-alarms (except spare inputs, because they have their latching or non-latching selections) will automatically reset once the triggering condition has cleared.

Enable: Warnings and pre-alarms will latched when triggered. To reset the alarm either an external reset must be applied to one of the inputs or the 'Reset' pushbutton operated, once the triggering condition has cleared.

MAINS FAILURE DETECTION EN/DIS

Disable: The module will not monitor the AC mains supply for failure. The AC mains instrumentation will still be active however.

Enable: The module will monitor the incoming AC mains supply. Should the supply go out side of limits the module will initiate its automatic mains failure sequence.

LOOK MAINS FAILURE FOR MAINS CONTACTOR EN/DIS

Disable: In the event of a mains failure the Gentrans En/d will attempt to maintain the supply to the load for the incoming AC mains supply until the generator is available to go on load. In the event of a generator failure the module will default back to the incoming AC mains supply. This provides a 'fail-safe system', ensuring that in the event of a system failure the load will still be fed from the AC mains supply.

Enable: As soon as the module detects a mains failure the mains contactor or breaker relay will be opened to remove the supply from the load. This is to prevent damage to the load in case of single-phase failure, especially useful if the load is a 3-phase motor or pump. The supply to the load will then be fed from the gen-set once it is available. In the event of generator failure the module will open the generator relay and remove the supply to the load until either the mains supply is restored or the generator is restarted.

ENGINE FUEL (DIESEL /GAS) SELECTION

Diesel or Gas engine can be selected.

If diesel engine selected:

STOP/FUEL SELECTION

Selection for the engine has Fuel or Stop solenoid.

STOP SOLEONID TIME

This timer is used if the unit is configured to operate an Energise to stop engine. It dictates the duration that the Stop Solenoid output will remain active after the module has detected the engine has come to rest. If the Stop Solenoid output is not configured, this timer will still operate, preventing an immediate restart.

Example: Start/stop diagram for Diesel Engine.

The formula signs and indices mean:

TPT	Preheating time	[s]
TCT	Engagement time	[s]
TRT	Interval between 2 start attempts	[s]
TDT	Engine delayed monitoring	[s]

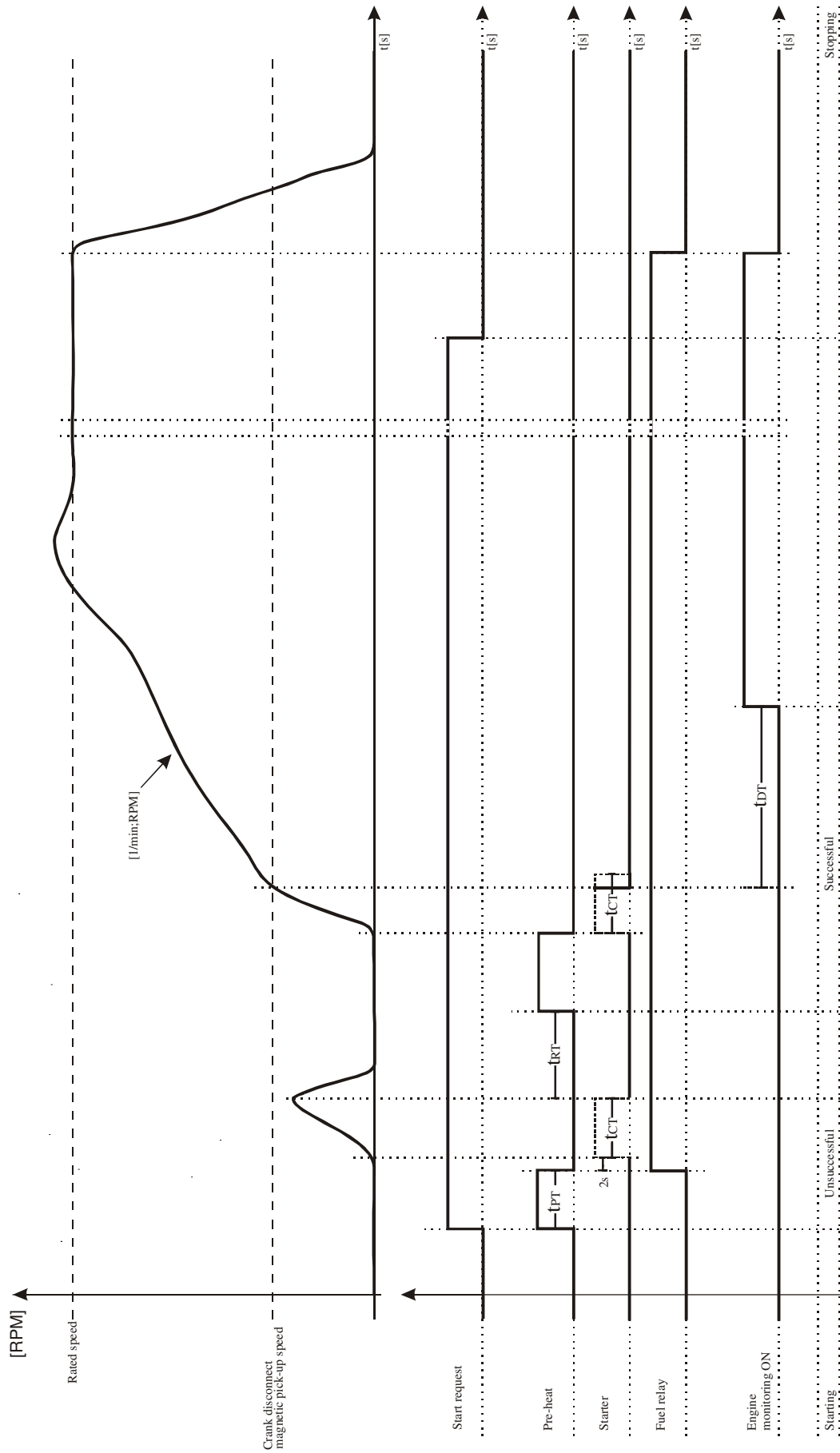

If gas engine selected:

IGNITION DELAY

With gas engines often a purging operation is desired before starting. With the engaging of the starter the ignition delay is started. If the 'min ignition speed' is reached after expiry of this time, the configurable relay output 'ignition' is set.

GAS VALVE DELAY

By setting the ignition relay the gas valve delay is started. After the expiry of the set time as long as the number of revolutions is higher than the minimum ignition speed, the gas valve is set. When the necessary engine shutdown process, gas valve is de-energised.

MIN IGNITION SPEED

After expiry of the ignition delay the number of revolutions set must be reached, so that the configurable relay output 'ignition' will be set.

Example: Start/stop diagram for Gas Engine.

The formula signs and indices mean:

TRT	Interval between 2 start attempts	[s]
TIT	Ignition delay	[s]
TGT	Gas valve delay	[s]
TDT	Engine delayed monitoring	[s]

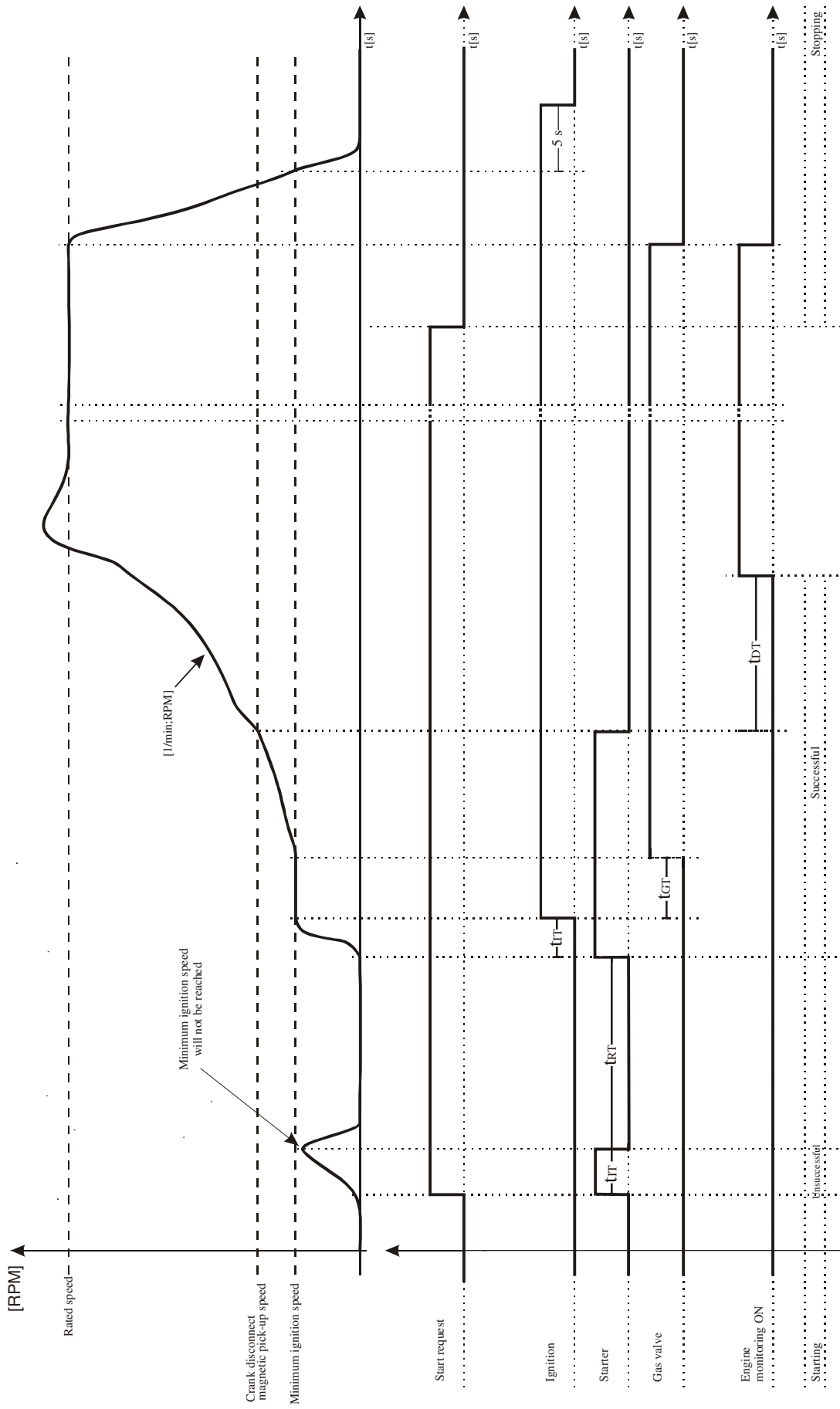

(EnSt) ENGINE STARTING OPTIONS page				
EnS1	<i>AUDIBLE ALARM PRIOR TO STARTING EN/DIS</i>	-	ENAB DIS	DIS
EnS2	<i>NUMBER OF START ATTEMPTS</i>	-	1 – 10	3
EnS3	<i>CRANKING TIME</i>	SEC	5 – 99	5
EnS4	<i>CRANK REST TIME</i>	SEC	5 – 99	10
EnS5	<i>MULTIPLE START ENGAGE ATTEMPTS E/D (PICK)</i>	-	ENAB DIS	DIS
EnS6	<i>ENGAGE ATTEMPT TIME (PICKUP)</i>	SEC	0.1 – 10.0	1.0
EnS7	<i>ENGAGE ATTEMPT REST TIME (PICKUP)</i>	SEC	0.1 – 10.0	1.0
EnS8	<i>PICKUP SENSOR FAIL DELAY(PICKUP)</i>	SEC	0.1 – 10.0	1.0

AUDIBLE ALARM PRIOR TO STARTING EN/DIS

ENABLE: The audible alarm will sound before the engine starts. The sounder will become active once the start delay is initialised, it will remain active until either the engine reaches crank disconnect speed or pre-heat timers are cancelled.

NUMBER OF START ATTEMPTS

This value is the number of times the module will attempt to start the generator. Should the generator start the module will not attempt further starts. If the generator does not start after the final attempt, the module will give a 'Fail to start' alarm.

CRANKING TIME

This is the maximum amount of time that the module will energise the starter motor for during starting attempts once the starter has engaged.

CRANK REST TIME

This is the amount of time the module will wait for between start attempts. This is to allow the starter motor to cool and the starter batteries to recover.

MULTIPLE START ENGAGE ATTEMPTS E/D

(Only available if using Magnetic pickup)

ENABLE: The module will monitor the flywheel to ensure that the starter motor has engaged. If it detects the starter has not meshed, it will de-energise the start relay and after a short delay it will attempt to re-engage the starter. This will be repeated until either the starter motor engages correctly or the number of engage attempts expires. Each start attempt can have a maximum number of attempts to engage the starter, this value is entered the box.
DISABLE: Normal operation, starter engagement with flywheel will not monitored.

ENGAGE ATTEMPT TIME

(Only available if using Magnetic pickup and multiple engage attempts)

This timer dictates the duration that the module will attempt to engage the starter motor during each engage attempt. If the magnetic pickup is not detecting movement of the flywheel when this timer expires the engage attempt will terminate. Once all engage attempts have been made the module will generate 'Fail to engage' alarm.

ENGAGE ATTEMPT REST TIME

(Only available if using Magnetic pickup and multiple engage attempts)

This timer dictates the duration that the module will wait between attempts to engage the starter.

PICKUP SENSOR FAIL DELAY

(Only available if using Magnetic pickup without multiple engage attempts)

This is only used if magnetic pickup speed sensing is selected. When cranking, the module must receive a speed signal within this time. If no signal is present the generator will be shutdown and Loss of Speed Sensing alarm given.

(EnC) ENGINE CRANK DISCONNECT page				
EnC1	CRANK DISCONNECT ON GEN. FREQUENCY	Hz	25.0 – 75.0	30.0
EnC2	CRANK DISCONNECT ON MAGNETIC PICKUP	RPM	500-6000	500
EnC3	CRANK DISCONNECT ON GEN. VOLTAGE	VAC	(dis)60 – 600	300
EnC4	CRANK DISCONNECT ON CHARGE ALT. VOLTAGE	VDC	(dis)6.0 – 30.0	dis
EnC5	CRANK DISCONNECT ON OIL PRESSURE	BAR	(dis)1.0-90.0	1.5

(GnS) GENERATOR SPEED SETTINGS page				
GnS1	GENERATOR UNDER SPEED	RPM	(dis)500 – 5000	1270
GnS2	GENERATOR UNDER SPEED PREALARM	RPM	(dis) 500 – 5000	1350
GnS3	GENERATOR UNDER SPEED PREALARM RETURN	RPM	500 – 5000	1380
GnS4	GENERATOR OVER SPEED PREALARM	RPM	(dis) 500 – 5000	1650
GnS5	GENERATOR OVER SPEED PREALARM RETURN	RPM	500 – 5000	1620
GnS6	GENERATOR OVER SPEED SHUTDOWN	RPM	500 – 5000	1740

(EnbA) ENGINE PLANT BATTERY page				
Enb1	BATTERY UNDERVOLTS WARNING	VDC	(dis)6.0 – 30.0	10.0
Enb2	BATTERY UNDERVOLTS WARNING RETURN	VDC	6.0 – 30.0	10.5
Enb3	BATT UNDERVOLTS VOLTS DELAY	Sec	0 – 9.9	1.0
Enb4	BATTERY OVERVOLTS WARNING	VDC	(dis)6.0 – 30.0	30.0
Enb5	BATTERY OVERVOLTS WARNING RETURN	VDC	6.0 – 30.0	29.5
Enb6	BATT OVERVOLTS DELAY	sec	0 – 9.9	1.0
Enb7	CHARGE ALTERNATOR WARNING	VDC	(dis)6.0 – 30.0	6.1

(Ain) ANALOGUE INPUTS page				
Ain1	OIL PRESSURE INPUT TYPE		Dis,nc,no,anlg	ANLG
Ain2	OIL PRESSURE PRE-ALARM	BAR	(dis)0.0 – 99.9	1.2
Ain3	OIL PRESSURE PRE-ALARM RETURN	BAR	0.0 – 99.9	1.4
Ain4	OIL PRESSURE SHUTDOWN	BAR	0.0 – 99.9	1.0
Ain5	TEMPERATURE INPUT TYPE		Dis,nc,no,anlg	ANLG
Ain6	TEMPERATURE PRE-ALARM	C	(dis)0 - 300	90
Ain7	TEMPERATURE PRE-ALARM RETURN	C	0 - 300	88
Ain8	TEMPERATURE SHUTDOWN	C	0 - 300	95
Ain9	LEVEL PRE-ALARM	L	(dis)0 - 300	80
Ai10	LEVEL PRE-ALARM RETURN	L	0 - 300	90
Ai11	LEVEL SHUTDOWN	L	0 - 300	70

OIL PRESSURE INPUT TYPE

This section is used to configure the Oil Pressure sender input.

dis: The Oil Pressure input will not be monitored.

1: digital & closed for low oil pressure : The Oil pressure input is fed from an engine mounted digital pressure switch. This switch returns a closed signal during low oil pressure conditions (and engine at rest), once oil pressure is established the switch will open.

2: digital & open for low oil pressure : The Oil pressure input is fed from an engine mounted digital pressure switch. This switch returns an open signal during low oil pressure conditions (and engine at rest), once oil pressure is established the switch will close.

3: analog : The Oil pressure input is connected to a resistive type engine mounted oil pressure transducer.

TEMPERATURE INPUT TYPE

This section is used to configure the Coolant Temperature sender input.

dis: The Coolant Temperature input will not be monitored.

1: digital & normally closed : The Coolant Temperature input is fed from an engine mounted digital temperature switch. This switch returns a closed signal during low

temperature, should the temperature rise above the switch manufacturers trip point the switch contact will open.

2: digital & normally open : The Coolant Temperature input is fed from an engine mounted digital temperature switch. This switch returns an open signal during low temperature, should the temperature rise above the switch manufacturers trip point the switch contact will close.

3: analog : The Coolant Temperature input is connected to a resistive type engine mounted temperature transducer.

(ALin) ANALOGUE SENDER LINEARISATIONS page				
Prr0	<i>OIL PRESSURE SENDER 0</i>	R	0 -650	16
PrU0	<i>OIL PRESSURE 0</i>	BAR	0 – 99.9	0.0
Prr1	<i>OIL PRESSURE SENDER 1</i>	R	0 -650	82
PrU1	<i>OIL PRESSURE 1</i>	BAR	0 –99.9	28.4
Prr2	<i>OIL PRESSURE SENDER 2</i>	R	0 -650	116
PrU2	<i>OIL PRESSURE 2</i>	BAR	0 –99.9	42.6
Prr3	<i>OIL PRESSURE SENDER 3</i>	R	0 -650	151
PrU3	<i>OIL PRESSURE 3</i>	BAR	0 –99.9	56.7
Prr4	<i>OIL PRESSURE SENDER 4</i>	R	0 -650	184
PrU4	<i>OIL PRESSURE 4</i>	BAR	0 –99.9	70.8
tpr0	<i>TEMPERATURE SENDER 0</i>	R	0 -650	650
tpU0	<i>TEMPERATURE 0</i>	C	0 -300	40
tpr1	<i>TEMPERATURE SENDER 1</i>	R	0 -650	134
tpU1	<i>TEMPERATURE 1</i>	C	0 -300	60
tpr2	<i>TEMPERATURE SENDER 2</i>	R	0 -650	51
tpU2	<i>TEMPERATURE 2</i>	C	0 -300	90
tpr3	<i>TEMPERATURE SENDER 3</i>	R	0 -650	44
tpU3	<i>TEMPERATURE 3</i>	C	0 -300	95
tpr4	<i>TEMPERATURE SENDER 4</i>	R	0 -650	38
tpU4	<i>TEMPERATURE 4</i>	C	0 -300	100
Ler0	<i>LEVEL SENDER 0</i>	R	0 -650	240
LeU0	<i>LEVEL 0</i>	-	0 -300	0
Ler1	<i>LEVEL SENDER 1</i>	R	0 -650	190
LeU1	<i>LEVEL 1</i>	-	0 -300	25
Ler2	<i>LEVEL SENDER 2</i>	R	0 -650	140
LeU2	<i>LEVEL 2</i>	-	0 -300	50
Ler3	<i>LEVEL SENDER 3</i>	R	0 -650	90
LeU3	<i>LEVEL 3</i>	-	0 -300	75
Ler4	<i>LEVEL SENDER 4</i>	R	0 -650	40
LeU4	<i>LEVEL 4</i>	-	0 -300	100

(in1) DIGITAL CONFIGURABLE INPUT (1) page				
in11	<i>DISABLE, USER CONFIGURED OR SELECT FROM LIST</i>		(dis)0 - 2	1
in12	<i>IF USER CONFIGURED -POLARITY (CLOSE TO ACTIVATE, OPEN TO ACTIVATE)</i>		0 - 1	0
in13	<i>IF USER CONFIGURED -INDICATION (STATUS, WARNING NON-LATCHING, WARNING LATCHING, ELECTRICAL TRIP, SHUTDOWN)</i>		0 - 4	0
in14	<i>IF USER CONFIGURED -ACTIVATION (ACTIVE FROM STARTING, ACTIVE FROM SAFETY ON, ALWAYS ACTIVE)</i>		0 - 2	2
in15	<i>IF SELECT FROM LIST</i> 0 REMOTE START 1 AUXILIARY MAINS FAIL 2 SIMULATE LAMP TEST BUTTON 3 SIMULATE HORN RESET BUTTON 4 SIMULATE ALARM RESET BUTTON 5 SIMULATE OFF BUTTON 6 SIMULATE AUTO BUTTON 7 SIMULATE TEST BUTTON 8 SIMULATE MANUAL BUTTON 9 SIMULATE START BUTTON 10 SIMULATE STOP BUTTON 11 GENERATOR CLOSED AUXILIARY 12 GENERATOR LOAD INHIBIT 13 MAINS CLOSED AUXILIARY 14 MAINS LOAD INHIBIT 15 AUTO RESTORE INHIBIT 16 AUTO START INHIBIT 17 PANEL LOCK 18 SCHEDULED RUNS INHIBITED 19 RESET MAINTENANCE ALARM 20 TRANSFER TO GENERATOR/OPEN MAINS 21 TRANSFER TO MAINS/OPEN GENERATOR 22 REMOTE INHIBIT 23 TEST ON LOAD		0 - 23	2
in16	<i>INPUT TIME DELAY</i>	SEC	0 - 250	5

(In2) DIGITAL CONFIGURABLE INPUT (2) page				
In21	<i>DISABLE, USER CONFIGURED OR SELECT FROM LIST</i>		(dis)0 - 2	1
In22	<i>IF USER CONFIGURED -POLARITY (CLOSE TO ACTIVATE, OPEN TO ACTIVATE)</i>		0 - 1	0
In23	<i>IF USER CONFIGURED -INDICATION (STATUS, WARNING NON-LATCHING, WARNING LATCHING, ELECTRICAL TRIP, SHUTDOWN)</i>		0 - 4	0
In24	<i>IF USER CONFIGURED -ACTIVATION (ACTIVE FROM STARTING, ACTIVE FROM SAFETY ON, ALWAYS ACTIVE) IF SELECT FROM LIST</i>		0 - 2	2
In25	0 REMOTE START 1 AUXILIARY MAINS FAIL 2 SIMULATE LAMP TEST BUTTON 3 SIMULATE HORN RESET BUTTON 4 SIMULATE ALARM RESET BUTTON 5 SIMULATE OFF BUTTON 6 SIMULATE AUTO BUTTON 7 SIMULATE TEST BUTTON 8 SIMULATE MANUAL BUTTON 9 SIMULATE START BUTTON 10 SIMULATE STOP BUTTON 11 GENERATOR CLOSED AUXILIARY 12 GENERATOR LOAD INHIBIT 13 MAINS CLOSED AUXILIARY 14 MAINS LOAD INHIBIT 15 AUTO RESTORE INHIBIT 16 AUTO START INHIBIT 17 PANEL LOCK 18 SCHEDULED RUNS INHIBITED 19 RESET MAINTENANCE ALARM 20 TRANSFER TO GENERATOR/OPEN MAINS 21 TRANSFER TO MAINS/OPEN GENERATOR 22 REMOTE INHIBIT 23 TEST ON LOAD		0 - 23	3
In26	<i>INPUT TIME DELAY</i>	SEC	0 - 250	5

(in3) DIGITAL CONFIGURABLE INPUT (3) page				
in31	<i>DISABLE, USER CONFIGURED OR SELECT FROM LIST</i>		(dis)0 - 2	1
in32	<i>IF USER CONFIGURED -POLARITY (CLOSE TO ACTIVATE, OPEN TO ACTIVATE)</i>		0 - 1	0
in33	<i>IF USER CONFIGURED -INDICATION (STATUS, WARNING NON-LATCHING, WARNING LATCHING, ELECTRICAL TRIP, SHUTDOWN)</i>		0 - 4	0
in34	<i>IF USER CONFIGURED -ACTIVATION (ACTIVE FROM STARTING, ACTIVE FROM SAFETY ON, ALWAYS ACTIVE) IF SELECT FROM LIST</i>		0 - 2	2
in35	0 REMOTE START 1 AUXILIARY MAINS FAIL 2 SIMULATE LAMP TEST BUTTON 3 SIMULATE HORN RESET BUTTON 4 SIMULATE ALARM RESET BUTTON 5 SIMULATE OFF BUTTON 6 SIMULATE AUTO BUTTON 7 SIMULATE TEST BUTTON 8 SIMULATE MANUAL BUTTON 9 SIMULATE START BUTTON 10 SIMULATE STOP BUTTON 11 GENERATOR CLOSED AUXILIARY 12 GENERATOR LOAD INHIBIT 13 MAINS CLOSED AUXILIARY 14 MAINS LOAD INHIBIT 15 AUTO RESTORE INHIBIT 16 AUTO START INHIBIT 17 PANEL LOCK 18 SCHEDULED RUNS INHIBITED 19 RESET MAINTENANCE ALARM 20 TRANSFER TO GENERATOR/OPEN MAINS 21 TRANSFER TO MAINS/OPEN GENERATOR 22 REMOTE INHIBIT 23 TEST ON LOAD		0 - 23	4
in36	<i>INPUT TIME DELAY</i>	SEC	0 - 250	5

(in4) DIGITAL CONFIGURABLE INPUT (4) page				
in41	<i>DISABLE, USER CONFIGURED OR SELECT FROM LIST</i>		(dis)0 - 2	2
in42	<i>IF USER CONFIGURED -POLARITY (CLOSE TO ACTIVATE, OPEN TO ACTIVATE)</i>		0 - 1	0
in43	<i>IF USER CONFIGURED -INDICATION(WARNING NON-LATCHING, WARNING LATCHING, ELECTRICAL TRIP, SHUTDOWN)</i>		1 - 4	1
in44	<i>IF USER CONFIGURED -ACTIVATION (ACTIVE FROM STARTING, ACTIVE FROM SAFETY ON, ALWAYS ACTIVE) IF SELECT FROM LIST</i>		0 - 2	2
in45	0 REMOTE START 1 AUXILIARY MAINS FAIL 2 SIMULATE LAMP TEST BUTTON 3 SIMULATE HORN RESET BUTTON 4 SIMULATE ALARM RESET BUTTON 5 SIMULATE OFF BUTTON 6 SIMULATE AUTO BUTTON 7 SIMULATE TEST BUTTON 8 SIMULATE MANUAL BUTTON 9 SIMULATE START BUTTON 10 SIMULATE STOP BUTTON 11 GENERATOR CLOSED AUXILIARY 12 GENERATOR LOAD INHIBIT 13 MAINS CLOSED AUXILIARY 14 MAINS LOAD INHIBIT 15 AUTO RESTORE INHIBIT 16 AUTO START INHIBIT 17 PANEL LOCK 18 SCHEDULED RUNS INHIBITED 19 RESET MAINTENANCE ALARM 20 TRANSFER TO GENERATOR/OPEN MAINS 21 TRANSFER TO MAINS/OPEN GENERATOR 22 REMOTE INHIBIT 23 TEST ON LOAD 24 LOW OIL PRESSURE		0 - 24	24
in46	<i>INPUT TIME DELAY</i>	SEC	0 - 250	0

(in5) DIGITAL CONFIGURABLE INPUT (5) page				
in51	<i>DISABLE, USER CONFIGURED OR SELECT FROM LIST</i>		(dis)0 - 2	2
in52	<i>IF USER CONFIGURED -POLARITY (CLOSE TO ACTIVATE, OPEN TO ACTIVATE)</i>		0 - 1	0
in53	<i>IF USER CONFIGURED -INDICATION(WARNING NON-LATCHING, WARNING LATCHING, ELECTRICAL TRIP, SHUTDOWN)</i>		1 - 4	1
in54	<i>IF USER CONFIGURED -ACTIVATION (ACTIVE FROM STARTING, ACTIVE FROM SAFETY ON, ALWAYS ACTIVE) IF SELECT FROM LIST</i>		0 - 2	2
in55	0 REMOTE START 1 AUXILIARY MAINS FAIL 2 SIMULATE LAMP TEST BUTTON 3 SIMULATE HORN RESET BUTTON 4 SIMULATE ALARM RESET BUTTON 5 SIMULATE OFF BUTTON 6 SIMULATE AUTO BUTTON 7 SIMULATE TEST BUTTON 8 SIMULATE MANUAL BUTTON 9 SIMULATE START BUTTON 10 SIMULATE STOP BUTTON 11 GENERATOR CLOSED AUXILIARY 12 GENERATOR LOAD INHIBIT 13 MAINS CLOSED AUXILIARY 14 MAINS LOAD INHIBIT 15 AUTO RESTORE INHIBIT 16 AUTO START INHIBIT 17 PANEL LOCK 18 SCHEDULED RUNS INHIBITED 19 RESET MAINTENANCE ALARM 20 TRANSFER TO GENERATOR/OPEN MAINS 21 TRANSFER TO MAINS/OPEN GENERATOR 22 REMOTE INHIBIT 23 TEST ON LOAD 24 HIGH TEMPERATURE		0 - 24	24
in56	<i>INPUT TIME DELAY</i>	SEC	0 - 250	0

(in6) DIGITAL CONFIGURABLE INPUT (6) page				
in61	<i>DISABLE, USER CONFIGURED OR SELECT FROM LIST</i>		(dis)0 - 2	1
in62	<i>IF USER CONFIGURED -POLARITY (CLOSE TO ACTIVATE, OPEN TO ACTIVATE)</i>		0 - 1	0
in63	<i>IF USER CONFIGURED -INDICATION(WARNING NON-LATCHING, WARNING LATCHING, ELECTRICAL TRIP, SHUTDOWN)</i>		1 – 4	1
in64	<i>IF USER CONFIGURED -ACTIVATION (ACTIVE FROM STARTING, ACTIVE FROM SAFETY ON, ALWAYS ACTIVE) IF SELECT FROM LIST</i>		0 – 2	2
in65	0 REMOTE START 1 AUXILIARY MAINS FAIL 2 SIMULATE LAMP TEST BUTTON 3 SIMULATE HORN RESET BUTTON 4 SIMULATE ALARM RESET BUTTON 5 SIMULATE OFF BUTTON 6 SIMULATE AUTO BUTTON 7 SIMULATE TEST BUTTON 8 SIMULATE MANUAL BUTTON 9 SIMULATE START BUTTON 10 SIMULATE STOP BUTTON 11 GENERATOR CLOSED AUXILIARY 12 GENERATOR LOAD INHIBIT 13 MAINS CLOSED AUXILIARY 14 MAINS LOAD INHIBIT 15 AUTO RESTORE INHIBIT 16 AUTO START INHIBIT 17 PANEL LOCK 18 SCHEDULED RUNS INHIBITED 19 RESET MAINTENANCE ALARM 20 TRANSFER TO GENERATOR/OPEN MAINS 21 TRANSFER TO MAINS/OPEN GENERATOR 22 REMOTE INHIBIT 23 TEST ON LOAD		0 – 23	7
in66	<i>INPUT TIME DELAY</i>	SEC	0 - 250	5

CONFIGURABLE INPUTS SELECTIONS

0 REMOTE START/STOP

In AUTO mode, if one of the configurable inputs are selected as 0 (Remote Start), the module doesn't perform the mains failure control in order to start the generator. In AUTO mode, if one of the configurable inputs are selected as 0 (Remote Start) and this input is active, then the module will perform the start sequence. If the input is passive module will perform the stop sequence.

1 AUXILIARY MAINS FAIL

The Eaom-210 Fd module will monitor the incoming single or three phase supply for Over Voltage, Under Voltage, Over Frequency or Under Frequency. It may be required to monitor a different mains supply or some aspect of the incoming mains not monitored by the Eaom-210 Fd. If the devices providing this additional monitoring are connected to operate this input, the Eaom-210 Fd will operate as if the incoming mains supply has fallen outside of limits, the generator will be instructed to start and take load. Removal of the input signal will cause the module to act if the mains has returned to within limits.

2 SIMULATE LAMP TEST BUTTON

This input mimic's the operation of the 'Lamp Test' button and is used to provide a remotely located Lamp Test push button.

3 SIMULATE HORN RESET BUTTON

This input mimic's the operation of the 'Horn Reset' button and is used to provide a remotely located Horn Reset push button.

4 SIMULATE ALARM RESET BUTTON

This input mimic's the operation of the 'Alarm Reset' button and is used to provide a remotely located Alarm Reset push button.

5 SIMULATE OFF BUTTON

This input mimic's the operation of the 'Off' button and is used to provide a remotely located Off mode push button.

6 SIMULATE AUTO BUTTON

This input mimic's the operation of the 'Auto' button and is used to provide a remotely located Auto mode push button.

7 SIMULATE TEST BUTTON

This input mimic's the operation of the 'Test' button and is used to provide a remotely located Test mode push button.

8 SIMULATE MANUAL BUTTON

This input mimic's the operation of the 'Manual' button and is used to provide a remotely located Manual mode push button.

9 SIMULATE START BUTTON

This input mimic's the operation of the 'Start' button and is used to provide a remotely located start push button.

10 SIMULATE STOP BUTTON

This input mimic's the operation of the 'Stop' button and is used to provide a remotely located Stop push button.

11 GENERATOR CLOSED AUXILIARY

This input is used to provide feedback to allow the Eaom-210 Fd to give true indication of the contactor or circuit breaker switching status. It should be connected to the generator load switching device auxiliary contact.

12 GENERATOR LOAD INHIBIT

This input is used to prevent the Eaom-210 Fd from loading the generator. If the generator is already on load, activating this input will cause the Eaom-210 Fd to unload the generator. Removing the input will allow the generator to be loaded again. **Note:** This input only operates to control the generator-switching device if the Eaom-210 Fd load switching logic is attempting load the generator. It will not control the generator-switching device when the mains is on load.

13 MAINS CLOSED AUXILIARY

This input is used to provide feedback to allow the Eaom-210 Fd to give true indication of the contactor or circuit breaker switching status. It should be connected to the generator load switching device auxiliary contact.

14 MAINS LOAD INHIBIT

This input is used to prevent the Eaom-210 Fd from loading the mains supply. If the manis supply is already on load, activating this input will cause the Eaom-210 Fd to unload the mains supply. Removing the input will allow the mains to be loaded again. **Note:** This input only operates to control the mains-switching device if the Eaom-210 Fd load switching logic

is attempting to load the mains. It will not control the mains-switching device when the generator is on load.

15 AUTO RESTORE INHIBIT

When module in the AUTO mode. In the event of a remote start / mains failure the generator will be instructed to start and take load. On removal of the remote start signal / mains return the module will continue to run the generator on load until this AUTO RESTORE INHIBIT input is removed. Once the input is removed the module will transfer the load back to the mains supply and follow a normal generator stop sequence. This input allows the module to be fitted as part of a system where the manual restoration to mains is controlled remotely or by an automated system.

16 AUTO START INHIBIT

This input is used to provide an over-ride function to prevent the Eaom-210 Fd from starting the generator in the event of a remote start / mains out of limits condition occurring. If this input is active and a remote start signal / mains failure occurs the Eaom-210 Fd will not give a start command to the generator. If this input signal is then removed, the Eaom-210 Fd will operate as if a remote start / mains failure has occurred, starting and loading the generator. This function can be used to give an 'AND' function so that a generator will only be called to start if the mains fails and another condition exists which requires the generator to run. If the 'Auto Start Inhibit' signal become active once more it will be ignored until the module has returned the mains supply on load and shutdown.

17 PANEL LOCK

This input is used to provide security to the installation. If the panel lock input is active, the module will not respond to operation of the mode select or start buttons. This allows the module to be placed into a specific mode (such as Auto) and than secured. The operation of the module is not affected and the operator will still be able to view the various instrumentation pages etc. **Note:** External control sources (i.e. Simulate Start Button) are not affected by the panel lock input and will continue to operate normally.

18 SCHEDULED RUNS INHIBITED

This input is used to prevent the generator for starting in the event of a programmed scheduled run occurring. While the input is active no scheduled runs will occur. If the input is active when a schedule run is called for, and is removed during the running period the gen-set will start and complete any remaining scheduled running time.

19 RESET MAINTENANCE ALARM

This input used to reset the maintenance alarm. When activated it will reset the maintenance counter to the pre-configured value (i.e. 250 hours). If the maintenance alarm is configured to monitor the monthly service interval this will also be reset to the pre-configured period. (i.e. 6 months).

20 TRANSFER TO GENERATOR/OPEN MAINS

This input is used to transfer the load to the generator when running in Manual mode.

21 TRANSFER TO MAINS/OPEN GENERATOR

This input is used to transfer the load to the mains supply when running in Manual mode.

22 REMOTE INHIBIT

In AUTO mode, if one of the configurable inputs are selected as 22 (Remote Inhibit) and this input is active, the module will inhibit the generator for starting. In the other hand, if this input is active while the generator was starting, the module will stop the generator.

23 TEST ON LOAD

If this input is active when the unit is in test mode, load is transferred to the generator to do the test on load. If the input is not active, test is done without load.

24 LOW OIL PRESSURE (FOR CONFIGURABLE INPUT-4)

This input is used as the oil pressure failure input.

24 HIGH TEMPERATURE (FOR CONFIGURABLE INPUT-5)

This input is used as the temperature failure input.

(out1) CONFIGURABLE OUTPUT (1) page

ou11	POLARITY (NORMALLY OPEN, NORMALLY CLOSED)		0 - 1	0
ou12	0 NOT USED 1 AUDIBLE ALARM 2 ALARM RESET 3 AUTO START INHIBIT 4 AUXILIARY MAINS FAILURE 5 BATTERY HIGH VOLTAGE 6 BATTERY LOW VOLTAGE 7 CALLING FOR SCHEDULED RUN 8 CHARGE ALTERNATOR FAILURE 9 COMMON ALARM 10 COMMON ELECTRICAL TRIP ALARM 11 COMMON SHUTDOWN ALARM 12 COMMON WARNING ALARM 13 COOLANT TEMPERATURE HIGH PRE-ALARM 14 COOLANT TEMPERATURE HIGH SHUTDOWN 15 COOLING DOWN TIMER IN PROGRESS 16 DELAYED ALARMS ACTIVE 17 DIGITAL INPUT1 ACTIVE 18 DIGITAL INPUT2 ACTIVE 19 DIGITAL INPUT3 ACTIVE 20 DIGITAL INPUT4 ACTIVE 21 DIGITAL INPUT5 ACTIVE 22 DIGITAL INPUT6 ACTIVE 23 EARTH FAULT 24 ELECTRIC COOLING FAN AFTER START 25 ELECTRIC COOLING FAN AFTER STOP 26 EMERGENCY STOP 27 FAIL TO START ALARM 28 FAIL TO STOP ALARM 29 FUEL RELAY ENERGISED 30 GAS ENGINE IGNITION OUTPUT 31 GENERATOR AT REST 32 GENERATOR AVAILABLE 33 GENERATOR CLOSED AUXILIARY 34 GENERATOR FAILED TO CLOSE 35 GENERATOR FAILED TO OPEN 36 GENERATOR HIGH FREQUENCY PRE-ALARM 37 GENERATOR HIGH FREQUENCY SHUTDOWN 38 GENERATOR HIGH VOLTAGE PRE-ALARM 39 GENERATOR HIGH VOLTAGE SHUTDOWN 40 GENERATOR LOAD INHIBIT 41 GENERATOR LOW FREQUENCY PRE-ALARM 42 GENERATOR LOW FREQUENCY SHUTDOWN 43 GENERATOR LOW VOLTAGE PRE-ALARM 44 GENERATOR LOW VOLTAGE SHUTDOWN 45 GENERATOR MINIMUM ACTIVE POWER 46 GENERATOR STOPPING 47 HORN OUTPUT 48 LAMP TEST 49 LEVEL PREALARM 50 LOSS OF MAGNETIC PICK-UP SPEED SIGNAL 51 MAINTENANCE DUE ALARM 52 MAINS CLOSED AUXILIARY 53 MAINS FAILED TO CLOSE 54 MAINS FAILED TO OPEN 55 MAINS FAILURE 56 MAINS HIGH FREQUENCY 57 MAINS HIGH VOLTAGE 58 MAINS LOAD INHIBIT 59 MAINS LOW FREQUENCY 60 MAINS LOW VOLTAGE 61 NO LOADING COMMAND 62 OIL PRESSURE LOW PRE-ALARM 63 OIL PRESSURE LOW SHUTDOWN 64 OVER CURRENT 65 OVERSPEED PRE-ALARM 66 OVERSPEED SHUTDOWN 67 PANEL LOCK 68 PRE-HEAT(during preheat timer) 69 PRE-HEAT(until end of cranking) 70 PRE-HEAT(until end of warming) 71 PRE-HEAT(until end safety on) 72 REMOTE START PRESENT 73 REMOTE STOP DELAY IN PROGRESS 74 SHORT CIRCUIT 75 START RELAY ENERGISED 76 STARTING ALARM 77 STARTING ALARMS ARMED 78 STOP BUTTON PRESSED 79 SYSTEM IN AUTO MODE 80 SYSTEM IN MANUAL MODE 81 SYSTEM IN OFF MODE 82 SYSTEM IN TEST MODE 83 UNDERSPEED SHUTDOWN 84 UNDERSPEED PRE-ALARM 85 WAITING FOR GENERATOR		0 - 85	47

(out2) CONFIGURABLE OUTPUT (2) page

ou21	POLARITY (NORMALLY OPEN, NORMALLY CLOSED)		0 - 1	0	
ou22	0 NOT USED 1 AUDIBLE ALARM 2 ALARM RESET 3 AUTO START INHIBIT 4 AUXILIARY MAINS FAILURE 5 BATTERY HIGH VOLTAGE 6 BATTERY LOW VOLTAGE 7 CALLING FOR SCHEDULED RUN 8 CHARGE ALTERNATOR FAILURE 9 COMMON ALARM 10 COMMON ELECTRICAL TRIP ALARM 11 COMMON SHUTDOWN ALARM 12 COMMON WARNING ALARM 13 COOLANT TEMPERATURE HIGH PRE-ALARM 14 COOLANT TEMPERATURE HIGH SHUTDOWN 15 COOLING DOWN TIMER IN PROGRESS 16 DELAYED ALARMS ACTIVE 17 DIGITAL INPUT1 ACTIVE 18 DIGITAL INPUT2 ACTIVE 19 DIGITAL INPUT3 ACTIVE 20 DIGITAL INPUT4 ACTIVE 21 DIGITAL INPUT5 ACTIVE 22 DIGITAL INPUT6 ACTIVE 23 EARTH FAULT 24 ELECTRIC COOLING FAN AFTER START 25 ELECTRIC COOLING FAN AFTER STOP 26 EMERGENCY STOP 27 FAIL TO START ALARM 28 FAIL TO STOP ALARM 29 FUEL RELAY ENERGISED 30 GAS ENGINE IGNITION OUTPUT 31 GENERATOR AT REST 32 GENERATOR AVAILABLE 33 GENERATOR CLOSED AUXILIARY 34 GENERATOR FAILED TO CLOSE 35 GENERATOR FAILED TO OPEN 36 GENERATOR HIGH FREQUENCY PRE-ALARM 37 GENERATOR HIGH FREQUENCY SHUTDOWN 38 GENERATOR HIGH VOLTAGE PRE-ALARM 39 GENERATOR HIGH VOLTAGE SHUTDOWN 40 GENERATOR LOAD INHIBIT 41 GENERATOR LOW FREQUENCY PRE-ALARM 42 GENERATOR LOW FREQUENCY SHUTDOWN 43 GENERATOR LOW VOLTAGE PRE-ALARM 44 GENERATOR LOW VOLTAGE SHUTDOWN 45 GENERATOR MINIMUM ACTIVE POWER 46 GENERATOR STOPPING 47 HORN OUTPUT 48 LAMP TEST 49 LEVEL PREALARM 50 LOSS OF MAGNETIC PICK-UP SPEED SIGNAL 51 MAINTENANCE DUE ALARM 52 MAINS CLOSED AUXILIARY 53 MAINS FAILED TO CLOSE 54 MAINS FAILED TO OPEN 55 MAINS FAILURE 56 MAINS HIGH FREQUENCY 57 MAINS HIGH VOLTAGE 58 MAINS LOAD INHIBIT 59 MAINS LOW FREQUENCY 60 MAINS LOW VOLTAGE 61 NO LOADING COMMAND 62 OIL PRESSURE LOW PRE-ALARM 63 OIL PRESSURE LOW SHUTDOWN 64 OVER CURRENT 65 OVERSPEED PRE-ALARM 66 OVERSPEED SHUTDOWN 67 PANEL LOCK 68 PRE-HEAT(during preheat timer) 69 PRE-HEAT(until end of cranking) 70 PRE-HEAT(until end of warming) 71 PRE-HEAT(until end safety on) 72 REMOTE START PRESENT 73 REMOTE STOP DELAY IN PROGRESS 74 SHORT CIRCUIT 75 START RELAY ENERGISED 76 STARTING ALARM 77 STARTING ALARMS ARMED 78 STOP BUTTON PRESSED 79 SYSTEM IN AUTO MODE 80 SYSTEM IN MANUAL MODE 81 SYSTEM IN OFF MODE 82 SYSTEM IN TEST MODE 83 UNDERSPEED SHUTDOWN 84 UNDERSPEED PRE-ALARM 85 WAITING FOR GENERATOR			0 - 85	9

(out3) CONFIGURABLE OUTPUT (3) page

ou31	POLARITY (NORMALLY OPEN, NORMALLY CLOSED)	0 - 1	0	
ou32	0 NOT USED 1 AUDIBLE ALARM 2 ALARM RESET 3 AUTO START INHIBIT 4 AUXILIARY MAINS FAILURE 5 BATTERY HIGH VOLTAGE 6 BATTERY LOW VOLTAGE 7 CALLING FOR SCHEDULED RUN 8 CHARGE ALTERNATOR FAILURE 9 COMMON ALARM 10 COMMON ELECTRICAL TRIP ALARM 11 COMMON SHUTDOWN ALARM 12 COMMON WARNING ALARM 13 COOLANT TEMPERATURE HIGH PRE-ALARM 14 COOLANT TEMPERATURE HIGH SHUTDOWN 15 COOLING DOWN TIMER IN PROGRESS 16 DELAYED ALARMS ACTIVE 17 DIGITAL INPUT1 ACTIVE 18 DIGITAL INPUT2 ACTIVE 19 DIGITAL INPUT3 ACTIVE 20 DIGITAL INPUT4 ACTIVE 21 DIGITAL INPUT5 ACTIVE 22 DIGITAL INPUT6 ACTIVE 23 EARTH FAULT 24 ELECTRIC COOLING FAN AFTER START 25 ELECTRIC COOLING FAN AFTER STOP 26 EMERGENCY STOP 27 FAIL TO START ALARM 28 FAIL TO STOP ALARM 29 FUEL RELAY ENERGISED 30 GAS ENGINE IGNITION OUTPUT 31 GENERATOR AT REST 32 GENERATOR AVAILABLE 33 GENERATOR CLOSED AUXILIARY 34 GENERATOR FAILED TO CLOSE 35 GENERATOR FAILED TO OPEN 36 GENERATOR HIGH FREQUENCY PRE-ALARM 37 GENERATOR HIGH FREQUENCY SHUTDOWN 38 GENERATOR HIGH VOLTAGE PRE-ALARM 39 GENERATOR HIGH VOLTAGE SHUTDOWN 40 GENERATOR LOAD INHIBIT 41 GENERATOR LOW FREQUENCY PRE-ALARM 42 GENERATOR LOW FREQUENCY SHUTDOWN 43 GENERATOR LOW VOLTAGE PRE-ALARM 44 GENERATOR LOW VOLTAGE SHUTDOWN 45 GENERATOR MINIMUM ACTIVE POWER 46 GENERATOR STOPPING 47 HORN OUTPUT 48 LAMP TEST 49 LEVEL PREALARM 50 LOSS OF MAGNETIC PICK-UP SPEED SIGNAL 51 MAINTENANCE DUE ALARM 52 MAINS CLOSED AUXILIARY 53 MAINS FAILED TO CLOSE 54 MAINS FAILED TO OPEN 55 MAINS FAILURE 56 MAINS HIGH FREQUENCY 57 MAINS HIGH VOLTAGE 58 MAINS LOAD INHIBIT 59 MAINS LOW FREQUENCY 60 MAINS LOW VOLTAGE 61 NO LOADING COMMAND 62 OIL PRESSURE LOW PRE-ALARM 63 OIL PRESSURE LOW SHUTDOWN 64 OVER CURRENT 65 OVERSPEED PRE-ALARM 66 OVERSPEED SHUTDOWN 67 PANEL LOCK 68 PRE-HEAT(during preheat timer) 69 PRE-HEAT(until end of cranking) 70 PRE-HEAT(until end of warming) 71 PRE-HEAT(until end safety on) 72 REMOTE START PRESENT 73 REMOTE STOP DELAY IN PROGRESS 74 SHORT CIRCUIT 75 START RELAY ENERGISED 76 STARTING ALARM 77 STARTING ALARMS ARMED 78 STOP BUTTON PRESSED 79 SYSTEM IN AUTO MODE 80 SYSTEM IN MANUAL MODE 81 SYSTEM IN OFF MODE 82 SYSTEM IN TEST MODE 83 UNDERSPEED SHUTDOWN 84 UNDERSPEED PRE-ALARM 85 WAITING FOR GENERATOR		0 - 85	9

(out4) CONFIGURABLE OUTPUT (4) page

ou41	POLARITY (NORMALLY OPEN, NORMALLY CLOSED)		0 - 1	0	
ou42	0 NOT USED 1 AUDIBLE ALARM 2 ALARM RESET 3 AUTO START INHIBIT 4 AUXILIARY MAINS FAILURE 5 BATTERY HIGH VOLTAGE 6 BATTERY LOW VOLTAGE 7 CALLING FOR SCHEDULED RUN 8 CHARGE ALTERNATOR FAILURE 9 COMMON ALARM 10 COMMON ELECTRICAL TRIP ALARM 11 COMMON SHUTDOWN ALARM 12 COMMON WARNING ALARM 13 COOLANT TEMPERATURE HIGH PRE-ALARM 14 COOLANT TEMPERATURE HIGH SHUTDOWN 15 COOLING DOWN TIMER IN PROGRESS 16 DELAYED ALARMS ACTIVE 17 DIGITAL INPUT1 ACTIVE 18 DIGITAL INPUT2 ACTIVE 19 DIGITAL INPUT3 ACTIVE 20 DIGITAL INPUT4 ACTIVE 21 DIGITAL INPUT5 ACTIVE 22 DIGITAL INPUT6 ACTIVE 23 EARTH FAULT 24 ELECTRIC COOLING FAN AFTER START 25 ELECTRIC COOLING FAN AFTER STOP 26 EMERGENCY STOP 27 FAIL TO START ALARM 28 FAIL TO STOP ALARM 29 FUEL RELAY ENERGISED 30 GAS ENGINE IGNITION OUTPUT 31 GENERATOR AT REST 32 GENERATOR AVAILABLE 33 GENERATOR CLOSED AUXILIARY 34 GENERATOR FAILED TO CLOSE 35 GENERATOR FAILED TO OPEN 36 GENERATOR HIGH FREQUENCY PRE-ALARM 37 GENERATOR HIGH FREQUENCY SHUTDOWN 38 GENERATOR HIGH VOLTAGE PRE-ALARM 39 GENERATOR HIGH VOLTAGE SHUTDOWN 40 GENERATOR LOAD INHIBIT 41 GENERATOR LOW FREQUENCY PRE-ALARM 42 GENERATOR LOW FREQUENCY SHUTDOWN 43 GENERATOR LOW VOLTAGE PRE-ALARM 44 GENERATOR LOW VOLTAGE SHUTDOWN 45 GENERATOR MINIMUM ACTIVE POWER 46 GENERATOR STOPPING 47 HORN OUTPUT 48 LAMP TEST 49 LEVEL PREALARM 50 LOSS OF MAGNETIC PICK-UP SPEED SIGNAL 51 MAINTENANCE DUE ALARM 52 MAINS CLOSED AUXILIARY 53 MAINS FAILED TO CLOSE 54 MAINS FAILED TO OPEN 55 MAINS FAILURE 56 MAINS HIGH FREQUENCY 57 MAINS HIGH VOLTAGE 58 MAINS LOAD INHIBIT 59 MAINS LOW FREQUENCY 60 MAINS LOW VOLTAGE 61 NO LOADING COMMAND 62 OIL PRESSURE LOW PRE-ALARM 63 OIL PRESSURE LOW SHUTDOWN 64 OVER CURRENT 65 OVERSPEED PRE-ALARM 66 OVERSPEED SHUTDOWN 67 PANEL LOCK 68 PRE-HEAT(during preheat timer) 69 PRE-HEAT(until end of cranking) 70 PRE-HEAT(until end of warming) 71 PRE-HEAT(until end safety on) 72 REMOTE START PRESENT 73 REMOTE STOP DELAY IN PROGRESS 74 SHORT CIRCUIT 75 START RELAY ENERGISED 76 STARTING ALARM 77 STARTING ALARMS ARMED 78 STOP BUTTON PRESSED 79 SYSTEM IN AUTO MODE 80 SYSTEM IN MANUAL MODE 81 SYSTEM IN OFF MODE 82 SYSTEM IN TEST MODE 83 UNDERSPEED SHUTDOWN 84 UNDERSPEED PRE-ALARM 85 WAITING FOR GENERATOR			0 - 85	24

CONFIGURABLE OUTPUTS SELECTIONS

0 NOT USED

Output is not used

1 AUDIBLE ALARM

The output indicates that the internal sounder is operating. It may be use for external sounder.

2 ALARM RESET

The output indicates that an alarm reset being performed. Once the alarm reset has been completed, the output become inactive again. The output could be used to give an external reset signal to external systems.

3 AUTO START INHIBIT

This output indicates that a digital input that has been configured as 'auto start inhibit' is active.

4 AUXILIARY MAINS FAILURE

This output indicates that a digital input that has been configured as 'auxiliary mains failure' is active.

5 BATTERY HIGH VOLTAGE

This output indicates that a battery high voltage alarm has occurred.

6 BATTERY LOW VOLTAGE

This output indicates that a battery low voltage alarm has occurred.

7 CALLING FOR SCHEDULED RUN

This output indicates that a scheduled run has been called for. If the module is in the 'auto' and mains okey, the module will change mode to 'test' and the generator will run if no shutdown alarms are present.

8 CHARGE ALTERNATOR FAILURE

This output indicates that a charging alternator failure has occurred

9 COMMON ALARM

This output indicates that a warning, electrical trip or shutdown alarm has been activated.

10 COMMON ELECTRICAL TRIP ALARM

This output indicates that an electrical trip alarm has been activated. This output can only be reset by removal of the fault and by then pressing the RESET button.

11 COMMON SHUTDOWN ALARM

This output indicates that a shutdown alarm has been activated. This output can only be reset by removal of the fault and by then pressing the RESET button or by using an external 'alarm reset' input.

12 COMMON WARNING ALARM

This output indicates that a warning alarm has been activated. This output is normally self-resetting on removal of the fault.

13 COOLANT TEMPERATURE HIGH PRE-ALARM

This output indicates that a high engine coolant temperature warning (pre-alarm) has occurred.

14 COOLANT TEMPERATURE HIGH SHUTDOWN

This output indicates that a high engine coolant temperature shutdown has occurred.

15 COOLING DOWN TIMER IN PROGRESS

This output source will be active when the cooling off-load timer is running.

16 DELAYED ALARMS ACTIVE

The output indicates that the delayed alarms now enabled. Can be used to control external logic circuitry.

17 DIGITAL INPUT1 ACTIVE

This output indicates that digital input 1 is active.

18 DIGITAL INPUT2 ACTIVE

This output indicates that digital input 2 is active.

19 DIGITAL INPUT3 ACTIVE

This output indicates that digital input 3 is active.

20 DIGITAL INPUT4 ACTIVE

This output indicates that digital input 4 is active.

21 DIGITAL INPUT5 ACTIVE

This output indicates that digital input 5 is active.

22 DIGITAL INPUT6 ACTIVE

This output indicates that digital input 6 is active.

23 EARTH FAULT

This output indicates that the module has detected that an earth fault exists on the generator output.

24 ELECTRIC COOLING FAN AFTER START

This output should energise as soon as engine has started so the fan should be running when the engine is running. This output should continue to operate for Cooling Fan Time parameter after engine has stopped.

25 ELECTRIC COOLING FAN AFTER STOP

This output indicates that can be made to energise for Cooling Fan Time parameter after the engine shuts down (to run an electric cooling fan on the radiator).

26 EMERGENCY STOP

This output indicates that an emergency stop alarm has occurred.

27 FAIL TO START ALARM

This output indicates that the engine has not started after the specified number of attempts.

28 FAIL TO STOP ALARM

This output indicates that the generator has failed to stop within the selected time

29 FUEL RELAY ENERGISED

The output mimics the operation of the fuel relay. It can be used to control external logic circuitry.

30 GAS ENGINE IGNITION OUTPUT

With the engaging of the starter the ignition delay is started. If the 'minimum ignition speed' is reached after expiry of this time, the configurable relay output 'ignition' is set. When the necessary engine shutdown process, firstly gas valve is de-energised. Then ignition output is de-energised that after 5 seconds when the engine speed become lower than 'minimum ignition speed'.

31 GENERATOR AT REST

The output indicates that the generator is not running.

32 GENERATOR AVAILABLE

This output indicates when the generator is ready to accept load, i.e. after safety on and warm up timers have timed out.

33 GENERATOR CLOSED AUXILIARY

This output indicates that a digital input that has been configured as 'generator closed auxiliary' is active.

34 GENERATOR FAILED TO CLOSE

This output source has intended to be used to indicate a failure of the generator contactor or breaker. It can only be used if the module is configured to use 'generator closed auxiliary' feedback.

35 GENERATOR FAILED TO OPEN

This output source has intended to be used to indicate a failure of the generator contactor or breaker. It can only be used if the module is configured to use 'generator closed auxiliary' feedback.

36 GENERATOR HIGH FREQUENCY PRE-ALARM

This output indicates that a generator high frequency warning (pre-alarm) has occurred.

37 GENERATOR HIGH FREQUENCY SHUTDOWN

This output indicates that a generator high frequency shutdown has occurred.

38 GENERATOR HIGH VOLTAGE PRE-ALARM

This output indicates that a generator high voltage warning (pre-alarm) has occurred.

39 GENERATOR HIGH VOLTAGE SHUTDOWN

This output indicates that a generator high voltage shutdown has occurred.

40 GENERATOR LOAD INHIBIT

This output indicates that a digital input has been configured as 'generator load inhibit' is active.

41 GENERATOR LOW FREQUENCY PRE-ALARM

This output indicates that a generator low frequency warning (pre-alarm) has occurred.

42 GENERATOR LOW FREQUENCY SHUTDOWN

This output indicates that a generator low frequency shutdown has occurred.

43 GENERATOR LOW VOLTAGE PRE-ALARM

This output indicates that a generator low voltage warning (pre-alarm) has occurred.

44 GENERATOR LOW VOLTAGE SHUTDOWN

This output indicates that a generator low voltage shutdown has occurred.

45 GENERATOR MINIMUM ACTIVE POWER

This output indicates that a generator minimum active power alarm has occurred.

46 GENERATOR STOPPING

This output source indicates that the engine has been instructed to stop but has not come to rest.

47 HORN OUTPUT

This output indicates that the horn alarm has occurred.

48 LAMP TEST

This output indicates that the module is performing a lamp test. Once the lamp test completed, the output will become inactive again. The output can be used to feed a lamp test on external modules or panel lamps.

49 LEVEL PREALARM

This output indicates that a level warning (pre-alarm) has occurred.

50 LOSS OF MAGNETIC PICK-UP SPEED SIGNAL

This output indicates that the magnetic pick up signal is not sufficient to be used by the module for speed monitoring. The alarm can only operate if the speed signal fails to appear during cranking. It is disabled if 'multiple attempts to engage' is selected. If the MPU fails during engine running this would result in an underspeed alarm.

51 MAINTENANCE DUE ALARM

This output indicates that the generator is now due for maintenance either because it has used all the available running hours or the periodic maintenance time has expired. To clear the output a maintenance reset must be performed.

52 MAINS CLOSED AUXILIARY

This output indicates that a digital input that has been configured as 'mains closed auxiliary' is active.

53 MAINS FAILED TO CLOSE

This output source has intended to be used to indicate a failure of the mains contactor or breaker. It can only be used if the module is configured to use 'mains closed auxiliary' feedback.

54 MAINS FAILED TO OPEN

This output source has intended to be used to indicate a failure of the mains contactor or breaker. It can only be used if the module is configured to use 'mains closed auxiliary' feedback.

55 MAINS FAILURE

This output indicates that the module has sensed that a failure of the incoming AC mains supply. This output will become active whenever the mains voltage or frequency goes out of limits, or if the auxiliary mains failure input active (if used) and the mains transient timer has expired.

56 MAINS HIGH FREQUENCY

This output indicates that the module has sensed that the incoming AC mains supply frequency has exceeded the frequency limit setting.

57 MAINS HIGH VOLTAGE

This output indicates that the module has sensed that the incoming AC mains supply voltage has exceeded the voltage limit setting.

58 MAINS LOAD INHIBIT

This output indicates that a digital input has been configured as 'mains load inhibit' is active.

59 MAINS LOW FREQUENCY

This output indicates that the module has sensed that the incoming AC mains supply frequency has fallen below the frequency setting.

60 MAINS LOW VOLTAGE

This output indicates that the module has sensed that the incoming AC mains supply voltage has fallen below the voltage limit setting.

61 NO LOADING COMMAND

This output indicates that the module is not calling of the generator contactor or breaker to be closed. Should the module close the generator contactor this output will become inactive.

62 OIL PRESSURE LOW PRE-ALARM

This output indicates that a low oil pressure warning (pre-alarm) has occurred.

63 OIL PRESSURE LOW SHUTDOWN

This output indicates that a low oil pressure shutdown has occurred.

64 OVER CURRENT ALARM

This output indicates that the over current trip level has been reached.

65 OVERSPEED PRE-ALARM

This output indicates that the over speed warning (pre-alarm) has occurred.

66 OVERSPEED SHUTDOWN

This output indicates that the over speed shutdown has occurred.

67 PANEL LOCK

This output indicates that the module 'panel lock' is active. If the panel lock input is active, the modul will not respond to operation of the Mode select or start buttons. This allows the module to be placed into a spesific mode (such as auto) and then secured.

68 PRE-HEAT(during preheat timer)

The output controls the pre-heater. Pre-heat output is available for the duration of pre-heat timer, which terminates prior to cranking.

69 PRE-HEAT(until end of cranking)

The output controls the pre-heater. As ' Pre-heat (during pre-heat timer)' mode but pre-heat is also available during cranking.

70 PRE-HEAT(until end of warming)

The output controls the pre-heater. As ' Pre-heat (until safety on)' but pre-heat continues to be available until the warm-up timer has elapsed.

71 PRE-HEAT(until end safety on)

The output controls the pre-heater. As ' Pre-heat (until end of cranking)' but pre-heat is also available while waiting for the delayed alarms to become active.

72 REMOTE START PRESENT

This output indicates that a digital input that has been configured as 'remote start' is active. This output could be used to pass the remote start signal on to elsewhere in the control system.

73 REMOTE STOP DELAY IN PROGRESS

This output source will be active to indicate that the return timer is running.

74 SHORT CIRCUIT

This output indicates that the module has detected a short circuit on the generator output.

75 START RELAY ENERGISED

The output mimics the operation of the start relay. Can be used to control external logic circuitry.

76 STARTING ALARM

This output is used to supply an external sounder with a signal that the engine is about to start. The output will be active during the start delay and pre-heat timer (if used).

77 STARTING ALARMS ARMED

The output indicates that the starting alarms are now enabled. It can be used to control external logic circuitry. Starting alarms are armed as soon as module commences starting of the engine and remain armed until the engine at rest.

78 STOP BUTTON PRESSED

This output indicates that the stop pushbutton being operated. Once the button is released the output will become inactive.

79 SYSTEM IN AUTO MODE

The output indicates that the module is in the Auto mode.

80 SYSTEM IN MANUAL MODE

The output indicates that the module is in the Manual mode.

81 SYSTEM IN OFF MODE

The output indicates that the module is in the Stop mode.

82 SYSTEM IN TEST MODE

The output indicates that the module is in the Test mode.

83 UNDERSPEED SHUTDOWN

This output indicates that an underspeed shutdown has occurred.

84 UNDERSPEED PRE-ALARM

This output indicates that an underspeed warning (pre-alarm) has occurred.

85 WAITING FOR GENERATOR

This output indicates that the engine has been instructed to start but has not yet become available. Once the generator becomes available this output will be in-active. (Available = generator frequency and voltage levels are above the 'loading' levels set in the configuration.)

(ti1) START TIMERS page				
ti11	<i>MAINS TRANSIENT DELAY</i>	sec	0 - 9999	0
ti12	<i>REMOTE START DELAY</i>	sec	0 - 3600	4
ti13	<i>REMOTE STOP DELAY</i>	sec	0 - 250	4
ti14	<i>PRE-HEAT</i>	Sec	0 – 250	3
ti15	<i>PRE-HEAT BYPASS</i>	Min	0 – 250	0
ti16	<i>SAFETY ON DELAY</i>	sec	0 - 99	8
ti17	<i>HORN DURATION</i>	sec	(dis)0 - 999	60
ti18	<i>CHARGE EXCITATION TIME</i>	sec	0 – 99(cont.)	15
ti19	<i>COOLING FAN TIME</i>	sec	0 - 250	180

MAINS TRANSIENT DELAY

This timer dictates how long a mains anomaly must be present before the module will respond to it. This can be used to prevent nuisance tripping when switching loads etc.

REMOTE START DELAY

This timer dictates how long the module will wait after it has received a remote start signal before it will attempt to start. This prevent un-necessary starting on a fluctuating mains supply etc.

REMOTE STOP DELAY

This timer dictates how long the module will wait after it has received a remote stop signal before it will attempt to stop. This prevent un-necessary stopping on a fluctuating mains supply etc.

PRE-HEAT

This timer dictates the duration that the pre-heat output will be active before an attempt is made to start the engine. Once this timer is expired cranking will commence.

PRE-HEAT BYPASS

This feature allows the module to start a hot engine without performing an un-necessary pre-heat delay. The bypass timer is triggered by the generator starting and actually being loaded. If the generator started but does not achieve loading then the timer will not be triggered. The bypass timer is initiated once the engine has come to rest. If any attempts to start are requested within the duration of the bypass timer the start sequence will bypass the pre-heat timer.

SAFETY ON DELAY

This timer dictates how long the module will ignore the Low Oil Pressure, High Engine Temperature, Underspeed, Undervolts and any other inputs configured as active from safety on. It allows the values such as oil pressure to rise to their operating values on starting without triggering an alarm. Once the timer has expired all alarm conditions are monitored again. If configured to use 'fast loading', should all the monitored conditions, such as oil pressure, come to expected state prior to the end of the safety on timer, the timer will be terminated prematurely ensuring maximum protection as soon as possible.

HORN DURATION

This timer dictates how long the horn will work after the last error detected. Once after this timer ended module will do horn reset.

CHARGE EXCITATION TIME

Charge excitation was selectable as momentary / continuous operation. This timer dictates how long the Charge excitation will active.

COOLING FAN TIME

This timer dictates how long the Cooling Fan will continue to operate.

(ti2) LOAD/STOPPING TIMERS page				
ti21	<i>WARMUP TIMER</i>	sec	0 - 250	3
ti22	<i>RETURN DELAY</i>	Sec	0 – 3600	5
ti23	<i>COOLING TIMER</i>	Min	0 – 99	1
ti24	<i>GENERATOR FREQUENCY ERROR CONTROL TIME</i>	Sec	0.0 – 10.0	1.0
ti25	<i>GENERATOR VOLTAGE ERROR CONTROL TIME</i>	Sec	0.0 – 10.0	1.0
ti26	<i>FAIL TO STOP TIME</i>	sec	15 – 99	30

WARMUP TIMER

This timer is initiated once the engine is up and running. It delays loading the generator until it has stabilised. Once this timer is expired the 'Close generator' signal will be given and the generator is available to be loaded.

RETURN DELAY

This timer dictates how long the module will wait before it will un-load the generator (back to the mains supply if AMF) and initialise it's run-on and shutdown cycle. This is ensure that the mains supply has stabilised before transferring the load back to mains.

COOLING TIMER

This is the time the generator is to run off-load once the load transfer signal has ceased. This gives the engine time to cool down before shutdown.

GENERATOR FREQUENCY ERROR CONTROL TIME

If firstly generator frequency is out of under and over set points this timer is initiated. If generator frequency is out of under and over set points when this timer expires a 'generator frequency error' alarm signal is generated.

GENERATOR VOLTAGE ERROR CONTROL TIME

If firstly generator voltage is out of under and over set points this timer is initiated. If generator voltage is out of under and over set points when this timer expires a 'generator voltage error' alarm signal is generated.

FAIL TO STOP TIME

Once the module has given a shutdown signal to the engine it expects the engine to come to rest. It monitors the Oil pressure and speed sensing sources and if they still indicate engine movement when this timer expires a 'Fail To Stop' alarm signal is generated.

(brEA) BREAKERS page				
brSL	<i>HARDWARE BREAKER SELECTION</i>		0 – 2	0
GbCC	<i>GEN CLOSE BREAKER CONTACT TYPE</i>	NO/NC	0 – 1	0
GbCr	<i>GEN CLOSE BREAKER RELAY TYPE</i>	NOR/PULS	0 – 1	0
GbCt	<i>GEN CLOSE TIMER</i>	Sec	1 – 250	5
GbOC	<i>GEN OPEN BREAKER CONTACT TYPE</i>	NO/NC	0 – 1	0
GbOr	<i>GEN OPEN BREAKER RELAY TYPE</i>	NOR/PULS	0 – 1	0
GbOt	<i>GEN OPEN TIMER</i>	Sec	1 – 250	5
MbCC	<i>MAIN CLOSE BREAKER CONTACT TYPE</i>	NO/NC	0 – 1	0
MbCr	<i>MAIN CLOSE BREAKER RELAY TYPE</i>	NOR/PULS	0 – 1	0
MbCt	<i>MAINS CLOSE TIMER</i>	Sec	1 – 250	5
MbOC	<i>MAIN OPEN BREAKER CONTACT TYPE</i>	NO/NC	0 – 1	0
MbOr	<i>MAIN OPEN BREAKER RELAY TYPE</i>	NOR/PULS	0 – 1	0
MbOt	<i>MAINS OPEN TIMER</i>	Sec	1 – 250	5

brCP	<i>BREAKER CLOSE PULSE TIME</i>	Sec	0.0 – 10.0	0.5
brOP	<i>BREAKER OPEN PULSE TIME</i>	Sec	0.0 – 10.0	0.5
trtm	<i>TRANSFER TIME</i>	Sec	0 - 250	2

HARDWARE BREAKER SELECTION

0- Mains and Gen schalters have only close drives and if close drive off schalter will open. Parameters; *GEN CLOSE BREAKER CONTACT TYPE*, *GEN CLOSE TIMER*(if gen closed input selected), *GEN OPEN TIMER*(if gen closed input selected), *MAIN CLOSE BREAKER CONTACT TYPE*, *MAINS CLOSE TIMER*(if mains closed input selected), *MAINS OPEN TIMER*(if mains closed input selected), *TRANSFER TIME*.

Example: If Hardware Breaker Selection parameter is selected as 0;

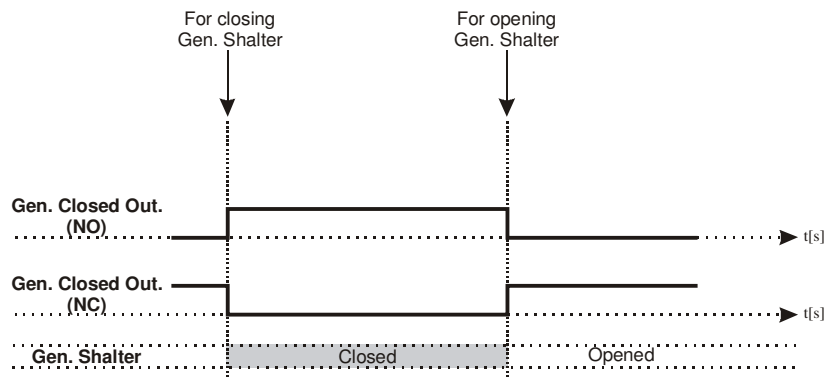

1- Mains and Gen schalters have only close drives, when want to schalter close, close breaker output on and after 1 sec. open breaker output on and after breaker close pulse time open breaker output will off. When want to schalter open close breaker output and open breaker output will off.

Parameters; *GEN CLOSE BREAKER CONTACT TYPE*, *GEN CLOSE TIMER*(if gen closed input selected), *GEN OPEN BREAKER CONTACT TYPE*, *GEN OPEN TIMER*(if gen closed input selected), *MAIN CLOSE BREAKER CONTACT TYPE*, *MAINS CLOSE TIMER*(if mains closed input selected), *MAIN OPEN BREAKER CONTACT TYPE*, *MAINS OPEN TIMER*(if mains closed input selected), *BREAKER CLOSE PULSE TIME*, *TRANSFER TIME*.

Example: If Hardware Breaker Selection parameter is selected as 1;

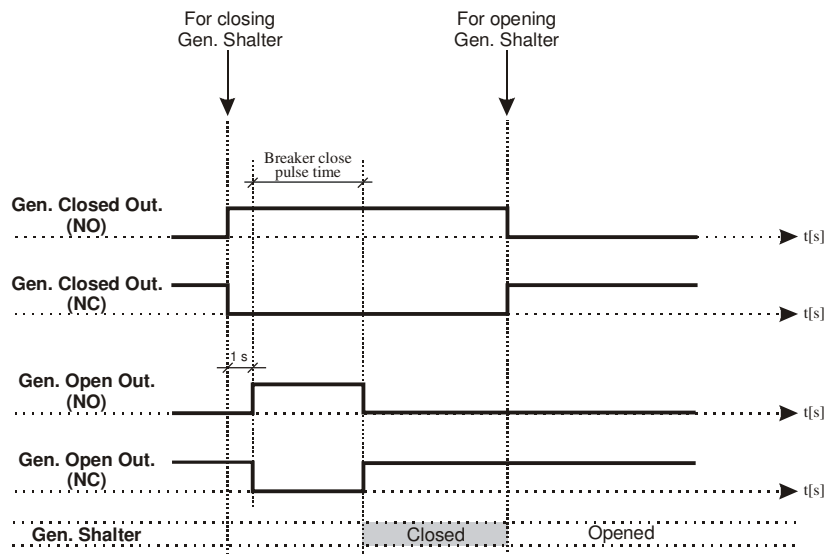

2- USER CONFIGURED: User can select all the schalter types.

Parameters; *GEN CLOSE BREAKER CONTACT TYPE*, *GEN CLOSE BREAKER RELAY TYPE*, *GEN CLOSE TIMER*(if gen closed input selected), *GEN OPEN BREAKER CONTACT TYPE*, *GEN OPEN BREAKER RELAY TYPE*, *GEN OPEN TIMER*(if gen closed input selected), *MAIN CLOSE BREAKER CONTACT TYPE*, *MAIN CLOSE BREAKER RELAY TYPE*, *MAINS CLOSE TIMER*(if mains closed input selected), *MAIN OPEN BREAKER CONTACT TYPE*, *MAIN OPEN BREAKER RELAY TYPE*, *MAINS OPEN TIMER*(if mains closed input selected), *BREAKER CLOSE PULSE TIME*(if Gen Close Breaker Relay Type or Main Close Breaker Relay Type parameter is selected as 1), *BREAKER OPEN PULSE TIME*(if Gen Open Breaker Relay Type or Main Open Breaker Relay Type parameter is selected as 1), *TRANSFER TIME*.

Example-1: If Hardware Breaker Selection parameter is selected as 2 (user configured), Gen. Close Breaker Relay Type parameter is selected as 0 (NOR) and Gen. Open Breaker Relay Type parameter is selected as 0 (NOR);

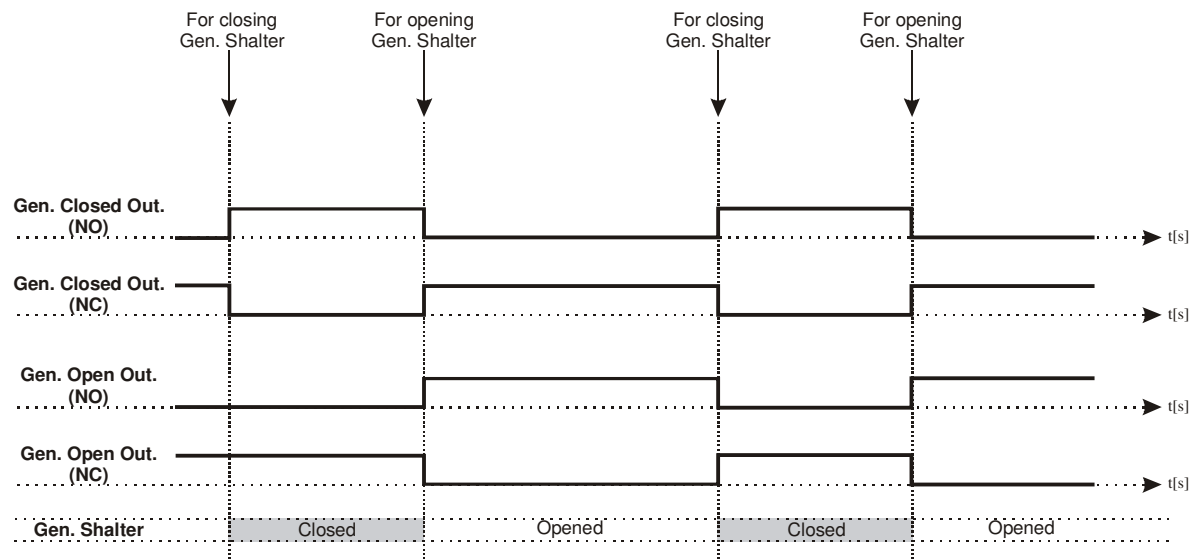

Example-2: If Hardware Breaker Selection parameter is selected as 2 (user configured), Gen. Close Breaker Relay Type parameter is selected as 1 (PULSE) and Gen. Open Breaker Relay Type parameter is selected as 0 (NOR);

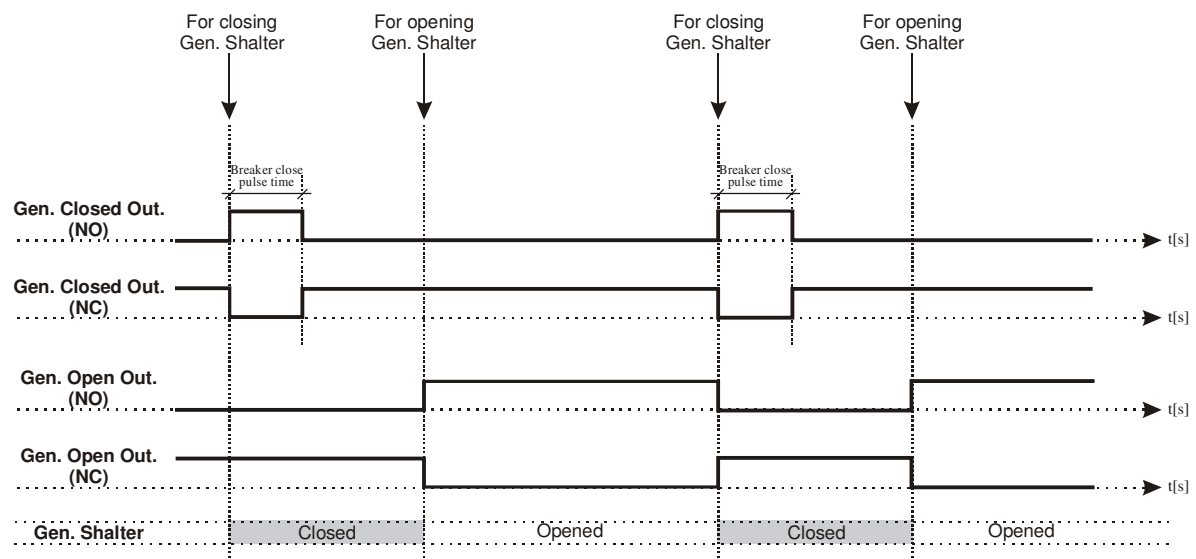

Example-3: If Hardware Breaker Selection parameter is selected as 2 (user configured), Gen. Close Breaker Relay Type parameter is selected as 0 (NOR) and Gen. Open Breaker Relay Type parameter is selected as 1 (PULSE);

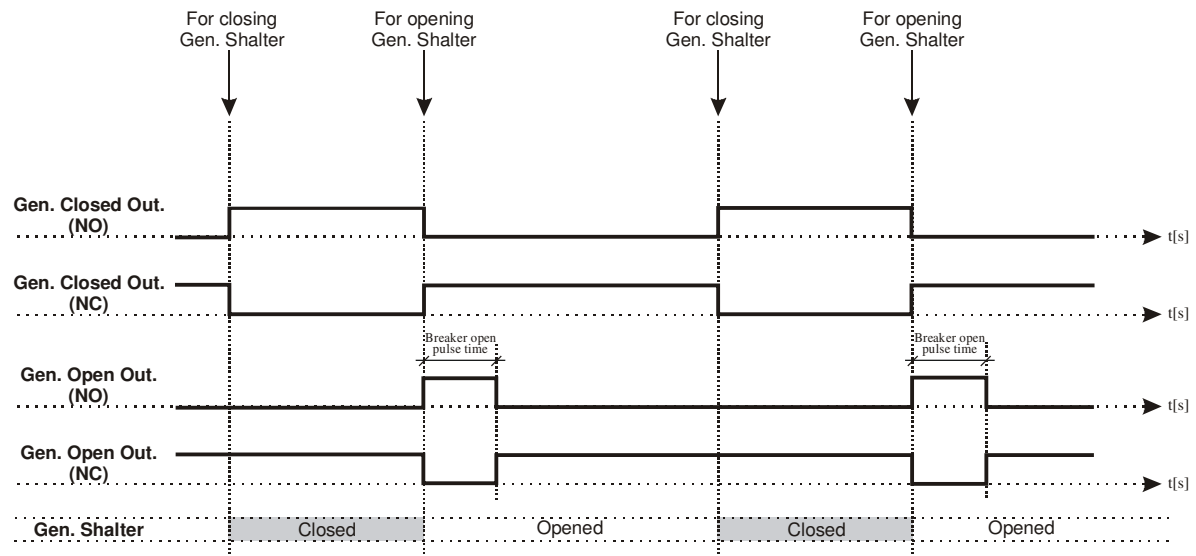

Example-4: If Hardware Breaker Selection parameter is selected as 2 (user configured), Gen. Close Breaker Relay Type parameter is selected as 1 (PULSE) and Gen. Open Breaker Relay Type parameter is selected as 1 (PULSE);

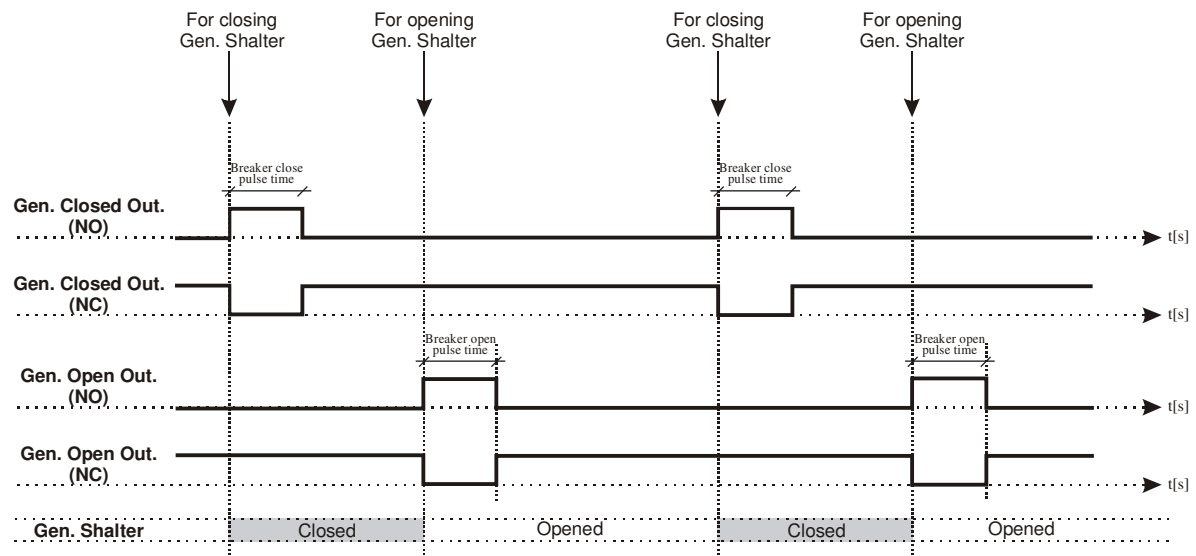

GEN. CLOSE TIMER

This is used to monitor the closure of the generator contactor or breaker. It will only operate if an auxiliary input is configured as 'Generator Closed Auxiliary' and connected to the auxiliary on the generator contactor or breaker. Once a generator closed signal is issued the 'gen close timer' is initiated. Should the 'Generator Closed Auxiliary' input become active the timer the 'gen close timer' is cancelled. If the timer expires and the 'Generator Closed Auxiliary' has not become active the module will issue a 'generator failed to close' alarm.

GEN. OPEN TIMER

This is used to monitor the opening of the generator contactor or breaker. It will only operate if an auxiliary input is configured as 'Generator Closed Auxiliary' and connected to the

auxiliary on the generator contactor or breaker. Once a generator open signal is issued the 'gen open timer' is initiated. Should the 'Generator Closed Auxiliary' input become in-active the timer 'gen open timer' is cancelled. If the timer expires and the 'Generator Closed Auxiliary' has not become in-active the module will issue a 'generator failed to open' alarm.

MAINS CLOSE TIMER

This is used to monitor the closure of the mains contactor or breaker. It will only operate if an auxiliary input is configured as 'Mains Closed Auxiliary' and connected to the auxiliary on the mains contactor or breaker. Once a mains closed signal is issued the 'mains close timer' is initiated. Should the 'Mains Closed Auxiliary' input become active the timer the 'mains close timer' is cancelled. If the timer expires and the 'Mains Closed Auxiliary' has not become active the module will issue a 'mains failed to close' alarm.

MAINS OPEN TIMER

This is used to monitor the opening of the mains contactor or breaker. It will only operate if an auxiliary input is configured as 'Mains Closed Auxiliary' and connected to the auxiliary on the mains contactor or breaker. Once a mains open signal is issued the 'mains open timer' is initiated. Should the 'Mains Closed Auxiliary' input become in-active the timer the 'mains open timer' is cancelled. If the timer expires and the 'Mains closed auxiliary' has not become in-active the module will issue a 'mains failed to open' alarm.

BREAKER CLOSE PULSE TIME

This is used to determine the duration of the Mains and Generator close signals. This timer is only used if Pulsed outputs are configured to be used.

BREAKER OPEN PULSE TIME

This is used to determine the duration of the Mains and Generator close signals. This timer is only used if Pulsed outputs are configured to be used.

TRANSFER TIME

This is used to allow for fixed duration transfer breaks when switching from mains to generator and back. It can be used to ensure that the supply is removed from the load for fixed period of time to allow pumps/motors to come to rest etc.

(Enm) ENGINE MAINTENANCE ALARM page				
Enm1	<i>RUNNING HOURS INTERVAL</i>	HOUR	(dis)0 - 9999	5000
Enm2	<i>MAINTENANCE DATE INTERVAL</i>	MONTH	(dis)0 - 12	6
Enm3	<i>FORCE ENGINE SHUTDOWN WHEN MAINTENANCE IS DUE EN/DIS</i>	-	ENAB DIS	DIS
Enm4	<i>ENGINE RUNNING HOUR (LSB)</i>	-	0 - 255	0
Enm5	<i>ENGINE RUNNING HOUR</i>	-	0 - 255	0
Enm6	<i>ENGINE RUNNING HOUR(MSB)</i>	-	0 - 14	0

(Com) COMMUNICATION page				
Co1	<i>SLAVE ADDRESS</i>		1 - 247	1
Co2	<i>BAUD RATE</i>			
	<i>0=1200</i>			
	<i>1=2400</i>			
	<i>2=4800</i>		0 - 4	3
	<i>3=9600</i>			
	<i>4=19200</i>			
Co3	<i>PARITY; 0= NONE, 1= ODD, 2= EVEN</i>		0 - 2	0
Co4	<i>STOP BIT</i>		0 - 1	0

(EHPG) EXERCISE page				
E1 C	<i>Generator exercise working time on Monday</i>	min	(dis)0 - 99	DIS
E1Hm	<i>Generator exercise work start time on Monday</i>	hour-min	0.0 – 23.59	0.0
E2 C	<i>Generator exercise working time on Tuesday</i>	min	(dis)0 – 99	DIS
E2Hm	<i>Generator exercise work start time on Tuesday</i>	hour-min	0.0 – 23.59	0.0
E3 C	<i>Generator exercise working time on Wednesday</i>	min	(dis)0 – 99	DIS
E3Hm	<i>Generator exercise work start time on Wednesday</i>	hour-min	0.0 – 23.59	0.0
E4 C	<i>Generator exercise working time on Thursday</i>	min	(dis)0 – 99	DIS
E4Hm	<i>Generator exercise work start time on Thursday</i>	hour-min	0.0 – 23.59	0.0
E5 C	<i>Generator exercise working time on Friday</i>	min	(dis)0 – 99	DIS
E5Hm	<i>Generator exercise work start time on Friday</i>	hour-min	0.0 – 23.59	0.0
E6 C	<i>Generator exercise working time on Saturday</i>	min	(dis)0 – 99	DIS
E6Hm	<i>Generator exercise work start time on Saturday</i>	hour-min	0.0 – 23.59	0.0
E7 C	<i>Generator exercise working time on Sunday</i>	min	(dis)0 – 99	DIS
E7Hm	<i>Generator exercise work start time on Sunday</i>	hour-min	0.0 – 23.59	0.0

Please enter the days of the weekly workdays for Exercise Function. Example:

E1 C	(dis)0	The exercise function is Mondays disabled.
	(10)	The exercise function is every Monday enabled for 10 minutes.
E1Hm	12.20	The exercise function is every Monday started at 12.20 o'clock (if it is enabled)
E2 C	(dis)0	The exercise function is Tuesdays disabled.
	(10)	The exercise function is every Tuesday enabled for 10 minutes.
E2Hm	12.20	The exercise function is every Tuesday started at 12.20 o'clock (if it is enabled)
E3 C	(dis)0	The exercise function is Wednesdays disabled.
	(10)	The exercise function is every Wednesday enabled for 10 minutes.
E3Hm	12.20	The exercise function is every Wednesday started at 12.20 o'clock (if it is enabled)
E4 C	(dis)0	The exercise function is Thursdays disabled.
	(10)	The exercise function is every Thursday enabled for 10 minutes.
E4Hm	12.20	The exercise function is every Thursday started at 12.20 o'clock (if it is enabled)
E5 C	(dis)0	The exercise function is Fridays disabled.
	(10)	The exercise function is every Friday enabled for 10 minutes.
E5Hm	12.20	The exercise function is every Friday started at 12.20 o'clock (if it is enabled)
E6 C	(dis)0	The exercise function is Saturdays disabled.
	(10)	The exercise function is every Saturday enabled for 10 minutes.
E6Hm	12.20	The exercise function is every Saturday started at 12.20 o'clock (if it is enabled)
E7 C	(dis)0	The exercise function is Sundays disabled.
	(10)	The exercise function is every Sunday enabled for 10 minutes.
E7Hm	12.20	The exercise function is every Sunday started at 12.20 o'clock (if it is enabled)

(DTE) DATE SETUP page				
YEAr	<i>YEAR</i>		0 - 99	
mon	<i>MONTH</i>		1 - 12	
DATE	<i>DATE</i>		1 - 31	
DAY	<i>DAY</i>		1 - 7	
Hour	<i>HOUR</i>		0 - 23	
min	<i>MIN</i>		0 - 59	
SEC	<i>SEC</i>		0 - 59	

(PAS) PASSWORD page				
oPPS	<i>OPERATOR PASSWORD</i>		0 - 9999	0
tCPS	<i>TECHNICIAN PASSWORD</i>		0 - 9999	0

OPERATOR PASSWORD

Use this option to change the Operator password. This password allows access to operator parameters section.

TECHNICIAN PASSWORD

Use this option to change the Technician password. It allows access to both operator and technician parameters section.



To prevent to changing unit program parameters by unauthorised personnel don't allow to the learning operator and technician passwords by the others. In case of this situation, change passwords immediately.

3.6 Pc Interface

The PC interface kit (EAOM-210 FD/PCIK) comprises the following:
 9 pin D connector/FCC68(4 pin) connection lead with 2 meters cable
 EAOM-210 FD V02/SW Communication software (CD)

3.6.1 Technical Specifications

RS-232 serial communication with Modbus RTU protocol
 Baud Rate from 1200 to 19200
 8 data bits, Parity; None, Odd or Even, Stop Bit; 0 or 1
 Maximum allowable cable length is 10 meters

3.6.2 RS-232 Serial Interface, Programming The Device Over PC or Modem

3.6.2.1 Cable Connection Between RS-232 Terminal of the Device and PC

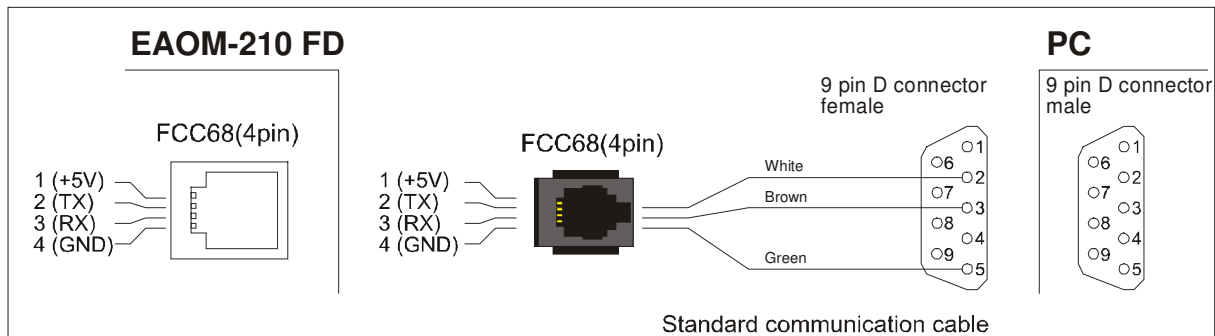

3.6.2.2 Cable Connection Between RS-232 Terminal of the Device and Modem

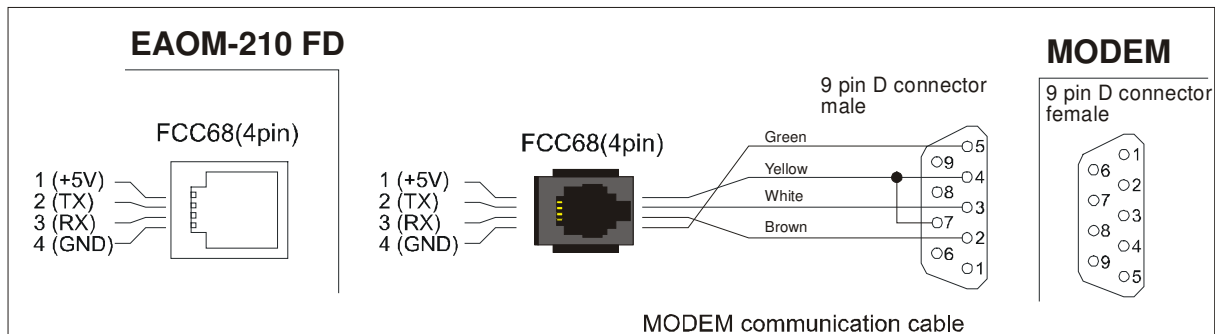

3.6.3 Installation Instruction

3.6.3.1 Minimum system requirements

Processor	:486 66MHz
Operating Systems	:Windows95/98, Windows NT
Ram	:16 Mbyte
Monitor	:14" SVGA (640x480 resolution)
Fixed Disk Free Space	:1 Mbyte
Disk Drive	:CD-ROM
Communication	:An RS232 communication port is needed to communicate with the EAOM-210 FD Unit

3.6.3.2 Installing EAOM-210 FD V02/SW

Insert the software CD into the CD-ROM drive on the PC
 Double click on MyComputer
 Then double click on CD-ROM drive

There will be a short delay while the CD-ROM is accessed, then the disk contents will be displayed.

Double click on “Install.exe”.

EAOM-210 FD V02/SW will be installed automatically on to your PC in its own folder(directory). It will also create “START MENU” items.

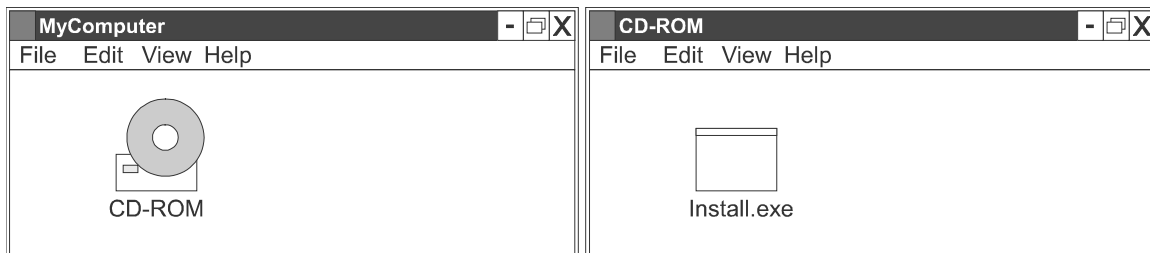

3.6.3.3 To Run EAOM-210 FD V02/SW communication software

Press the START icon

Then select Programs → EAOM-210 FD V02 SW(Folder) → EAOM-210 FD V02

Then click on EAOM-210 FD V02.

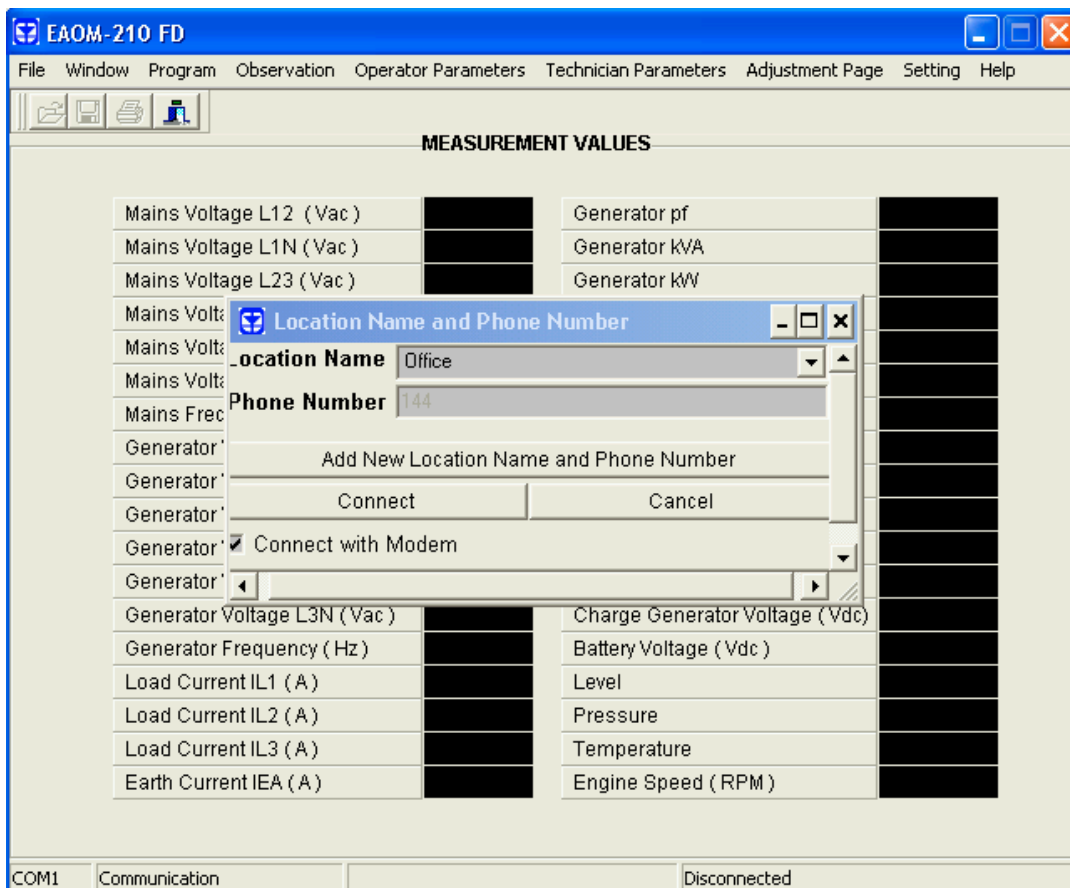

When the program runs firstly, a window is shown to determine how the connection will be established: over modem or RS-232 communication port. This selection is made with the ‘Connect with Modem’ check box. If the comport settings are correct, when ‘Connect’ button is pressed, connection is established. With ‘Add New Phone Number’ button, user can access to the window below and save the location name and phone number for using to connect with modem.

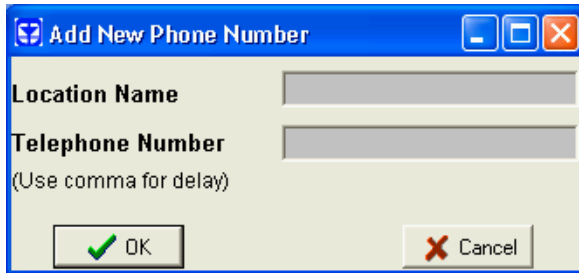

Firstly, enter phone number and location name (It is used to remember where the phone number belongs) and press 'Ok' button for saving these values.

When the connection is established, main screen is shown;

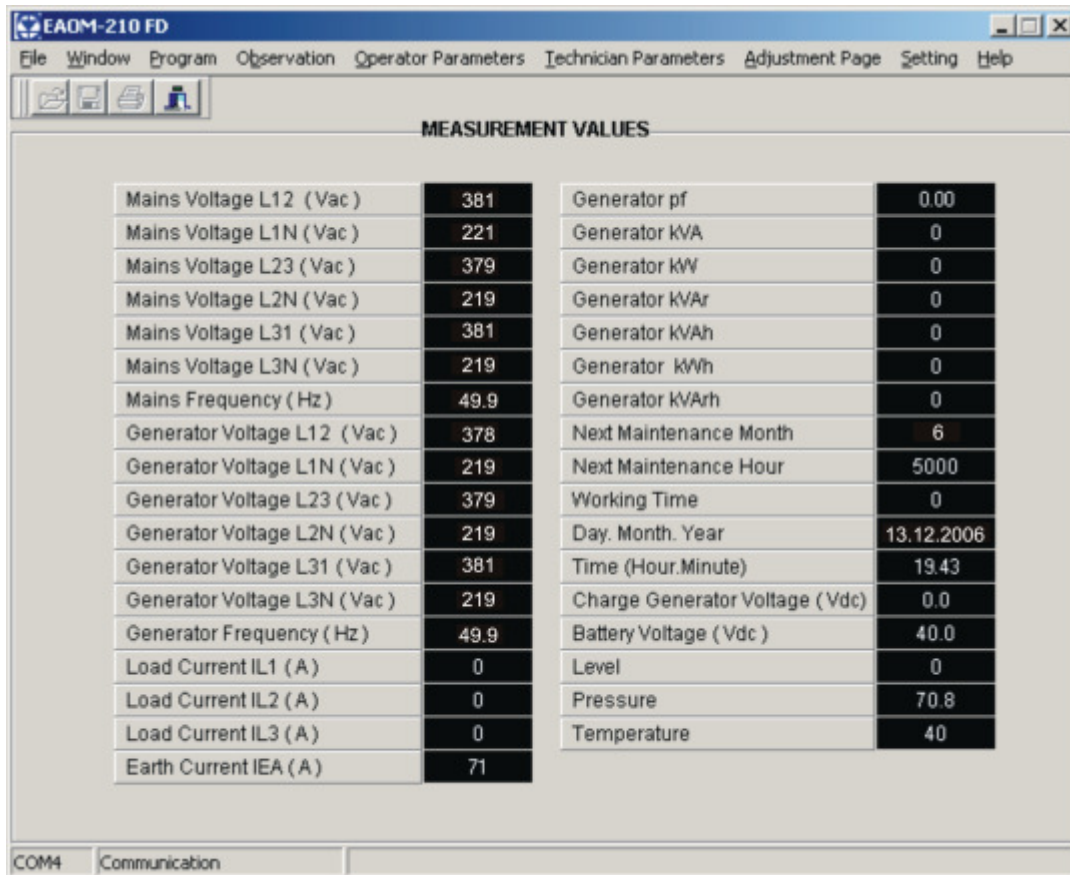

3.6.4 Description

EAOM-210 FD unit communicates with PC by means of EAOM-210 FD/PCIK. With EAOM-210 FD V00/SW ,the EAOM-210 FD unit's parameters and status information can be reached over PC easily. Operator and Technician parameters can be viewed. Parameters are password protected.

3.6.4.1 Main Menu

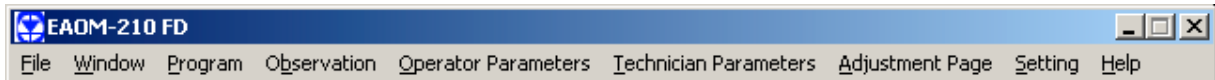

File Menu

This menu allows the user to save configuration files to the disc, read from disc and write to disc.

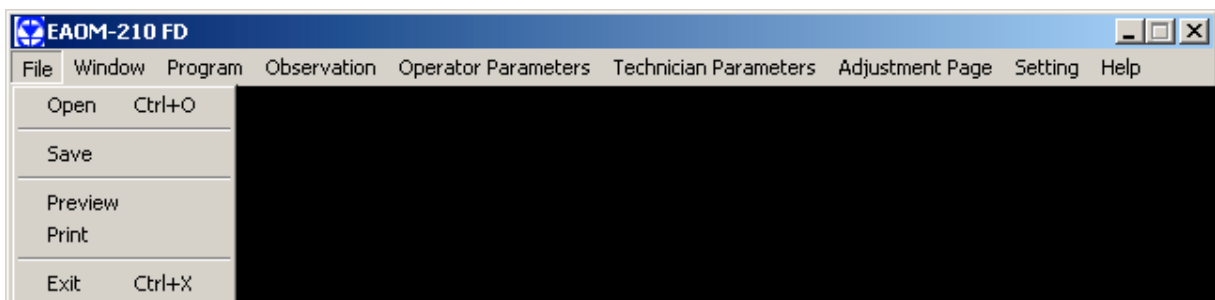

Open :This menu allows the user to load the registered configuration files to PC.

For example: Click 'Open' in File menu. Choose configuration file which includes operator or technician parameters on Open Dialog Box. When user clicks 'Open' button on Open Dialog Box parameters will be transferred to PC window.

Save :This menu allows the user to save the parameters with a name defined by user.

For example: Click 'Save' in File menu. After choosing where to save the file, enter the file name. When user clicks 'Save' button on Save Dialog Box, all parameters will be saved to the file that user determine.

Preview : This menu allows the user to preview the operator parameters, when the user to come into the Operator Parameters section. It allows the user to preview the technician parameters, when the user to come into the Technician Parameters section. It allows the user to preview the Event Logs, when the user to come into the Events section.

Print :This menu allows the user to print the parameters.

Exit :With this menu user can exit from the EAOM-210 FD V00/SW.

Window Menu

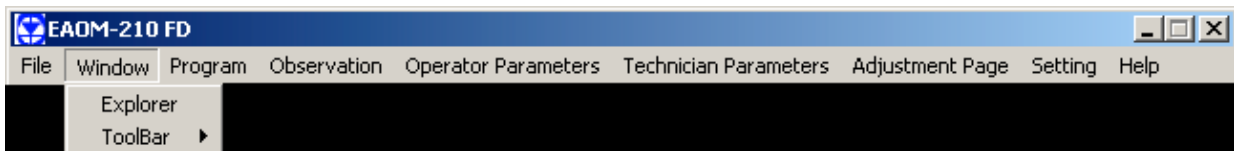

Explorer: This menu allows the user to reach quickly the Observation, Operator Parameters and Technician Parameters sections.

Toolbar: Toolbar on/off

Program Menu

This menu is active during the Operator or Technician Parameters Section is open. With this menu user can load parameters from EAOM-210 FD unit to PC or from PC to EAOM-210 FD unit.



Download :With this menu user can load parameters from PC to EAOM-210 FD.

For loading parameters from PC to EAOM-210 FD follow the steps below.

Download This Page to the Controller:

While the operator parameters window is showing, If user clicks “Download This Page to the Controller” in Program menu, only parameters in the related page is loaded from PC to device. While the technician parameters window is showing, If user clicks “Download This Page to the Controller” in Program menu, only parameters in the related page is loaded from PC to device.

Download All Parameters to the Controller:

While the operator parameters window is showing, If user clicks “Download All Parameters to the Controller” in Program menu, all of the operator parameters is loaded from PC to device. While the technician parameters window is showing, If user clicks “Download All Parameters to the Controller” in Program menu, all of the technician parameters is loaded from PC to device.

Upload :User can load the parameters that is stored on EAOM-210 FD unit to PC.

For loading parameters from EAOM-210 FD unit to PC follow the steps below.

Upload This Page from the Controller:

While the operator parameters window is showing, If user clicks “Upload This Page from the Controller” in Program menu, only parameters in the related page is loaded from device to PC. While the technician parameters window is showing, If user clicks “Upload This Page from the Controller” in Program menu, only parameters in the related page is loaded from device to PC.

Upload All Parameters from the Controller:

While the operator parameters window is showing, If user clicks “Upload All Parameters from the Controller” in Program menu, all of the operator parameters is loaded from device to PC. While the technician parameters window is showing, If user clicks “Upload All Parameters from the Controller” in Program menu, all of the technician parameters is loaded from device to PC.

Add New Phone Number:

User can be saved the phone number which is used for connecting with the modem.

Observation Menu

There are four sub-menus in this menu: Measurement Values, Failures, Events and Output & Modes.

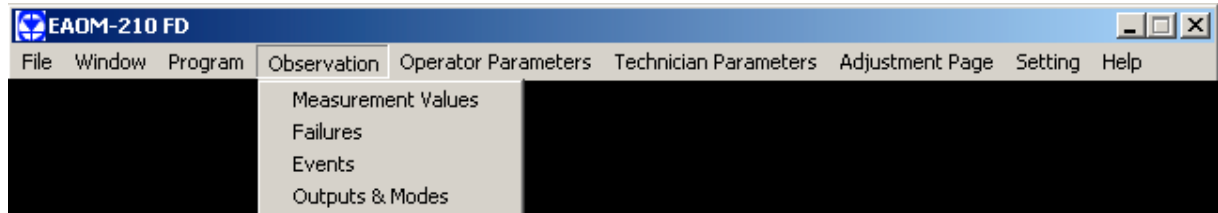

Measurement Values:

The screenshot shows the 'MEASUREMENT VALUES' window in the EAOM-210 FD software. The window displays a table of various electrical and generator parameters and their current values.

Mains Voltage L12 (Vac)	381	Generator pf	0.00
Mains Voltage L1N (Vac)	221	Generator kVA	0
Mains Voltage L23 (Vac)	379	Generator kW	0
Mains Voltage L2N (Vac)	219	Generator kVAr	0
Mains Voltage L31 (Vac)	381	Generator kVAh	0
Mains Voltage L3N (Vac)	219	Generator kWh	0
Mains Frequency (Hz)	49.9	Generator kVArh	0
Generator Voltage L12 (Vac)	378	Next Maintenance Month	6
Generator Voltage L1N (Vac)	219	Next Maintenance Hour	5000
Generator Voltage L23 (Vac)	379	Working Time	0
Generator Voltage L2N (Vac)	219	Day. Month. Year	13.12.2006
Generator Voltage L31 (Vac)	381	Time (Hour.Minute)	19.43
Generator Voltage L3N (Vac)	219	Charge Generator Voltage (Vdc)	0.0
Generator Frequency (Hz)	49.9	Battery Voltage (Vdc)	40.0
Load Current IL1 (A)	0	Level	0
Load Current IL2 (A)	0	Pressure	70.8
Load Current IL3 (A)	0	Temperature	40
Earth Current IEA (A)	71		

In this window the values listed below can be observed:

- Mains volts (L1-N, L2-N, L3-N)
- Mains volts (L1-L2, L2-L3, L3-L1)
- Mains Hz
- Generator volts (L1-N, L2-N, L3-N)
- Generator volts (L1-L2, L2-L3, L3-L1)
- Generator Hz
- Load amps (IL1, IL2, IL3)
- Earth current (IEA)
- Generator pf
- Generator kVA
- Generator kW
- Generator kVAr
- Generator kVAh
- Generator kWh

Generator kVAh
 Next maintenance
 Working time
 Real time
 Charge generator voltage
 Battery Voltage
 Level
 Pressure
 Temperature
 Engine speed (Rpm)

Failures:

EAOM-210 FD

File Window Program Observation Operator Parameters Technician Parameters Adjustment Page Setting Help

FAILURES

Error

Spare 4 (SP4.E)	Over Speed (OSP.E)	Earth Fault (EF.Er)	Battery High (Bt.EH)	Short Circuit (SC.Er)
Spare 5 (SP5.E)	Under Speed (USP.E)	Fuel Level (LVL.E)	Maintenance (M.Er)	Generator Stop (StP.E)
Spare 6 (SP6.E)	Speed Loss (SPE.L)	Battery Low (Bt.EL)	Over Current (OC.Er)	Reverse Power (RP.Er)

Pre-Alarm

- Generator Temp. (TP.PA)
- Generator Over Voltage (GOV.P)
- Generator Under Voltage (GUV.P)
- Generator Under Frequency (GUF.P)
- Generator Over Frequency (GOF.P)
- Oil Pressure (PrS.P)
- Over Speed (OSP.P)
- Under Speed (USP.P)
- Fuel Level (LVL.P)

Warning

- Reverse Power (RP.ur)
- Earth Fault (EF.ur)
- Over Current (OC.ur)
- Short Circuit (SC.ur)

Electrical Trip

- Reverse Power (RP.tr)
- Earth Fault (EF.tr)
- Short Circuit (SC.tr)
- Over Current (OC.tr)

Emergency Stop

- Multiple Engage Fail
- Failed To Start
- Low Oil Pressure
- High Temperature
- Speed Failure
- Voltage Failure
- Charging Fail
- Spare 1
- Spare 2
- Spare 3

Alarm

- Mains Breaker Not Opened (MB.OA)
- Mains Breaker Not Closed (MB.CA)
- Generator Breaker Not Opened (GB.OA)
- Generator Breaker Not Closed (GB.CA)

COM4 Communication

In this window the failures listed below can be observed:

Failed to start
 Low oil pressure
 High temperature
 Voltage failure
 Speed failure
 Charging fail
 Spare 1
 Spare 2
 Spare 3
 38 different error messages

Events:

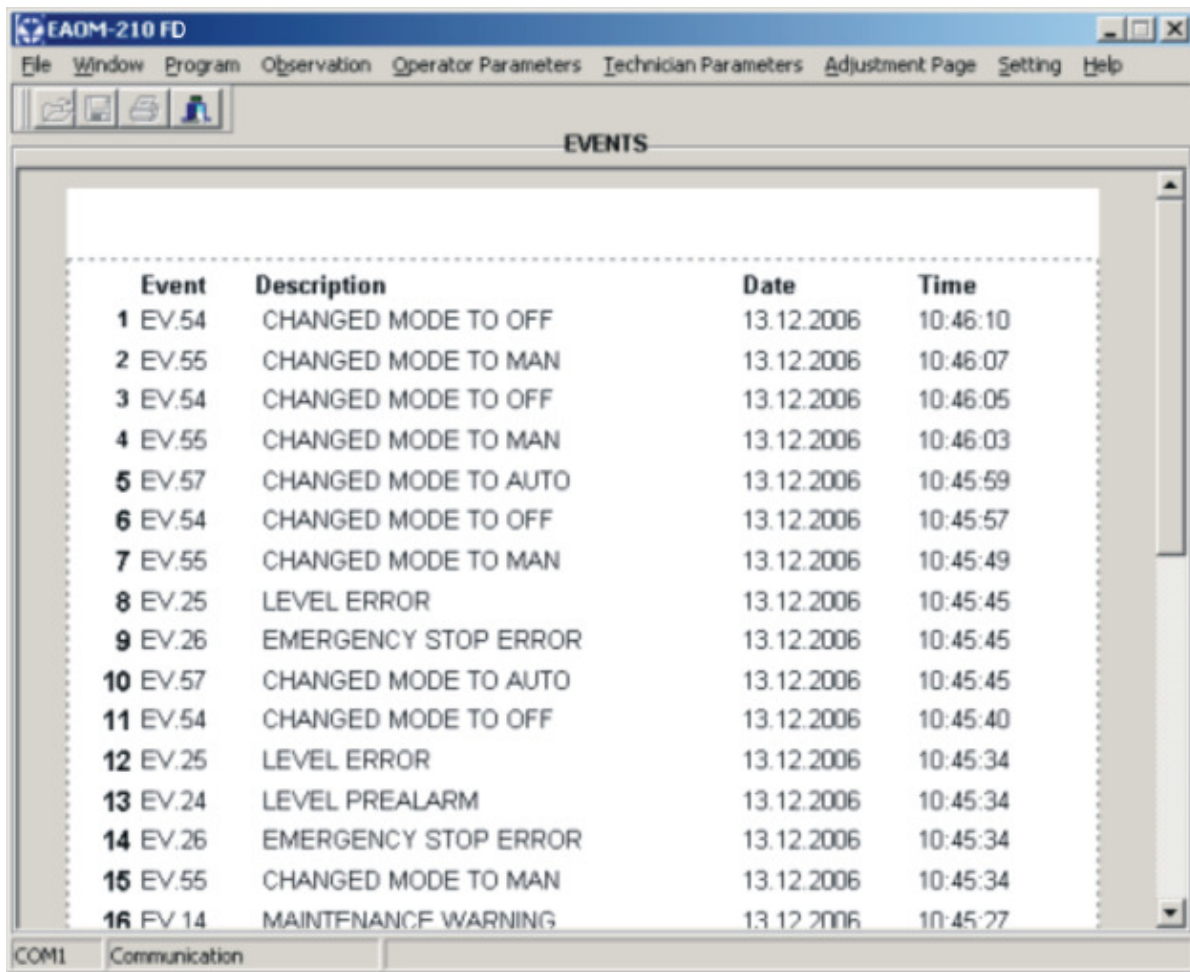

The screenshot shows a software window titled 'EAOM-210 FD'. The menu bar includes 'File', 'Window', 'Program', 'Observation', 'Operator Parameters', 'Technician Parameters', 'Adjustment Page', 'Setting', and 'Help'. Below the menu bar is a toolbar with several icons. The main area is titled 'EVENTS' and contains a table with the following data:

Event	Description	Date	Time
1 EV.54	CHANGED MODE TO OFF	13.12.2006	10:46:10
2 EV.55	CHANGED MODE TO MAN	13.12.2006	10:46:07
3 EV.54	CHANGED MODE TO OFF	13.12.2006	10:46:05
4 EV.55	CHANGED MODE TO MAN	13.12.2006	10:46:03
5 EV.57	CHANGED MODE TO AUTO	13.12.2006	10:45:59
6 EV.54	CHANGED MODE TO OFF	13.12.2006	10:45:57
7 EV.55	CHANGED MODE TO MAN	13.12.2006	10:45:49
8 EV.25	LEVEL ERROR	13.12.2006	10:45:45
9 EV.26	EMERGENCY STOP ERROR	13.12.2006	10:45:45
10 EV.57	CHANGED MODE TO AUTO	13.12.2006	10:45:45
11 EV.54	CHANGED MODE TO OFF	13.12.2006	10:45:40
12 EV.25	LEVEL ERROR	13.12.2006	10:45:34
13 EV.24	LEVEL PREALARM	13.12.2006	10:45:34
14 EV.26	EMERGENCY STOP ERROR	13.12.2006	10:45:34
15 EV.55	CHANGED MODE TO MAN	13.12.2006	10:45:34
16 EV.14	MAINTENANCE WARNING	13.12.2006	10:45:27

At the bottom of the window, there is a status bar with 'COM1' and 'Communication'.

In this window the last 32 Event logs can be observed:

Outputs & Modes:

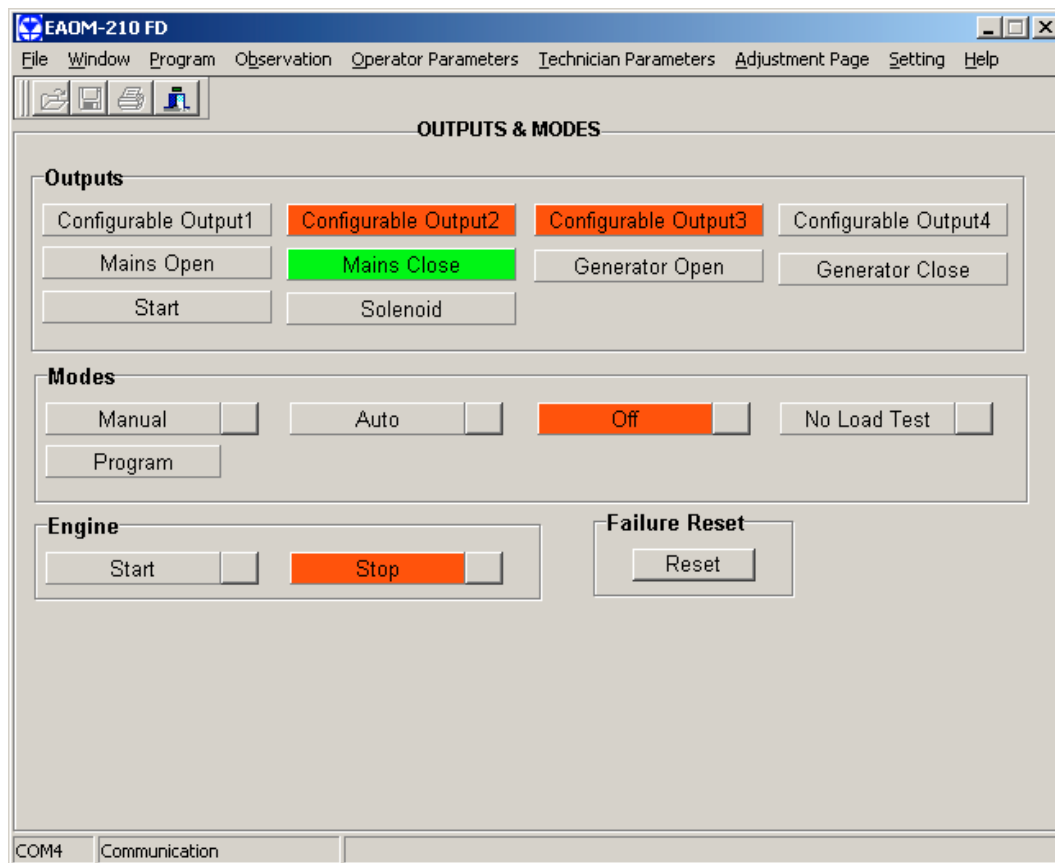

In this window the parameters listed below can be observed:

Outputs:

- Configurable output1
- Configurable output2
- Configurable output3
- Configurable output4
- Start
- Mains open
- Mains close
- Generator open
- Generator close
- Solenoid

Modes:

- Manual mode and button for remote control
- No Load Test mode and button for remote control
- Auto mode and button for remote control
- Program
- Off mode and button for remote control

Engine status:

- Start position and button for remote control
- Stop position and button for remote control

Failure Reset:

- Reset button for remote control

Operator Parameters Menu

Operator can reach the parameters in this menu. Parameters are password protected. When the operator password is entered, it is compared with operator password that is registered on EAOM-210 FD unit.

Entering To Operator Parameters Section

Click Mains Level in Operator Parameter menu. Then Operator Password is monitored. Enter the Operator Password and click OK button. If the password is correct, first page of the operator parameters (Mains Levels page) will be viewed.

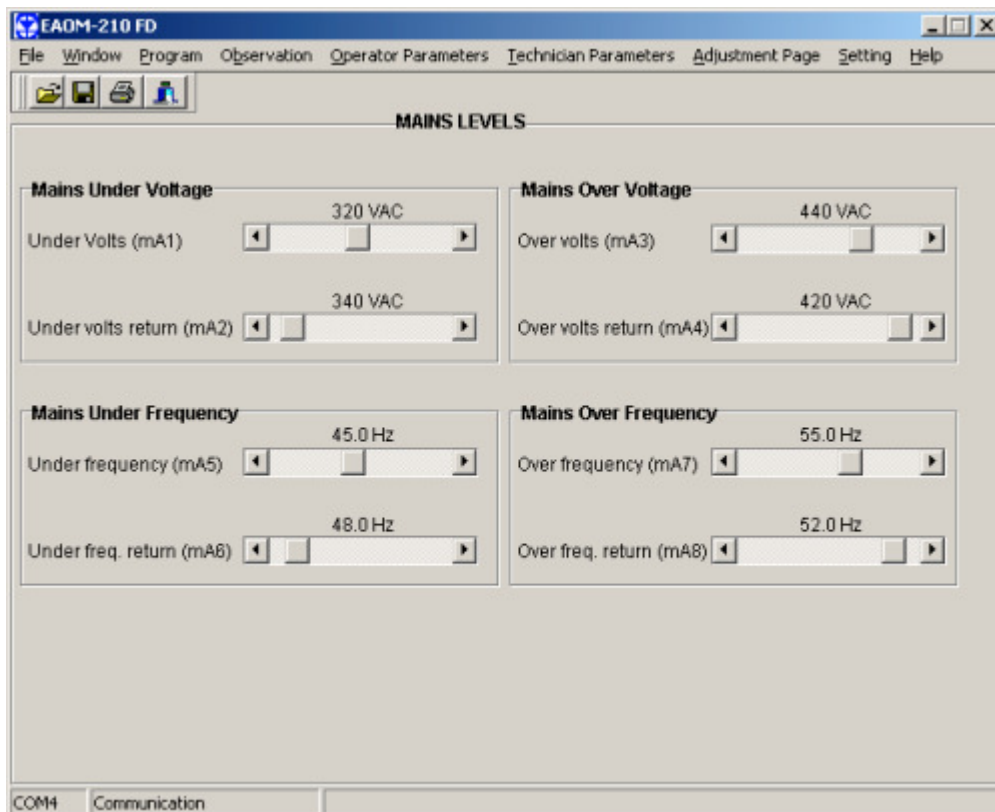
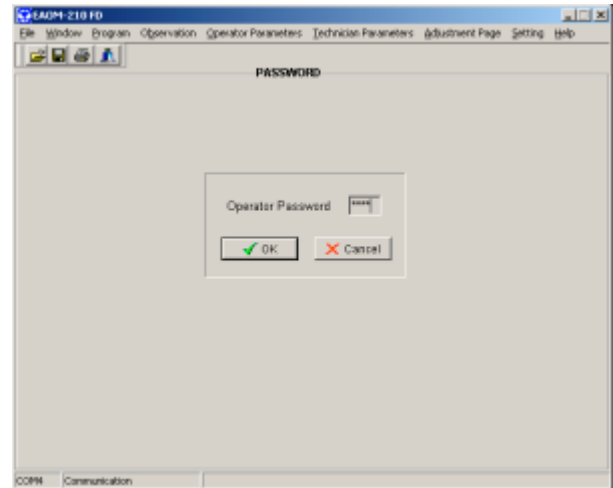
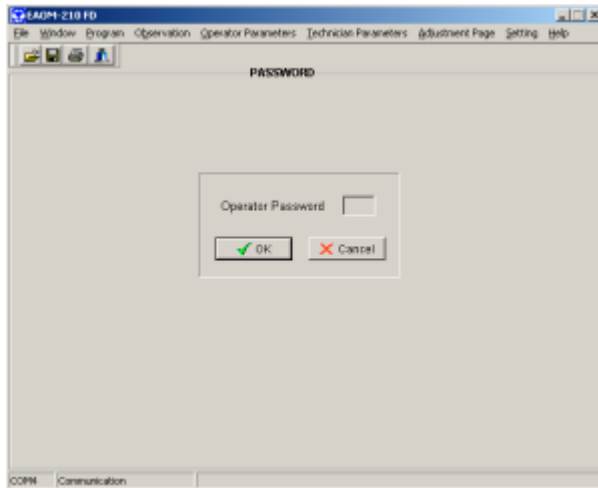

Technician Parameters Menu

All parameters can be viewed in this menu. Parameters are password protected. When the technician password is entered, it is compared with technician password that is registered on EAOM-210 FD unit.

Entering To Technician Parameters Section

Click Mains Level in Technician Parameter menu. Then Technician Password is monitored. Enter the Technician Password and click OK button. If the password is correct, first page of the technician parameters (Mains Levels page) will be viewed.

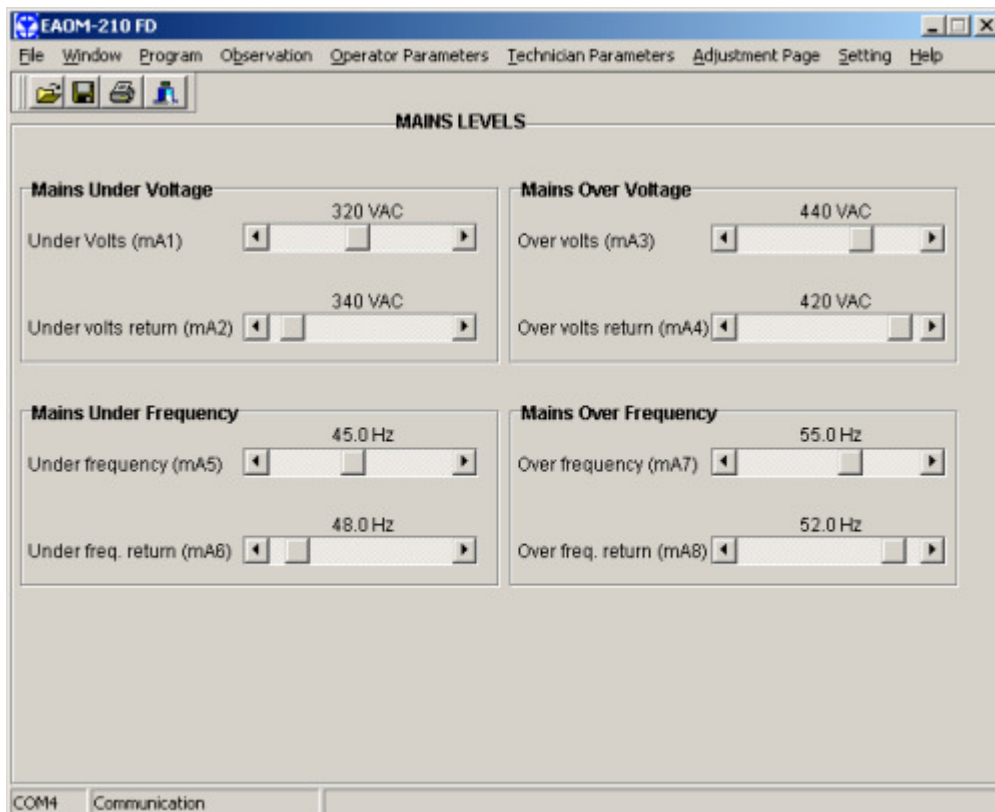
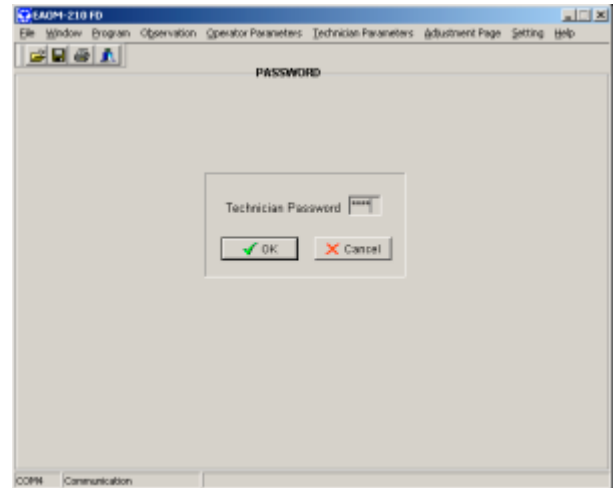
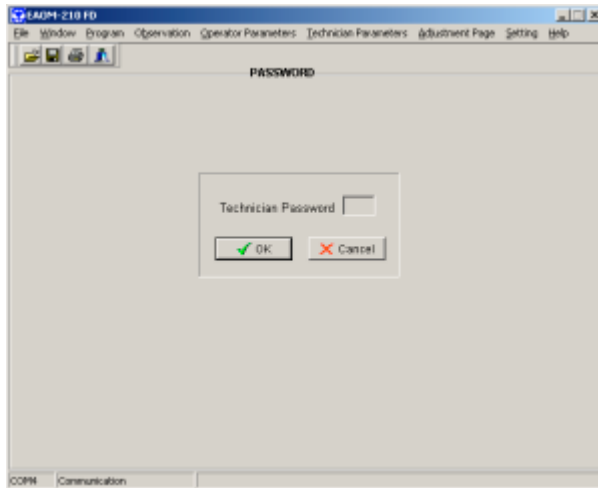

Adjustment Page (Calibration) Menu

There is one sub-menu in this menu: Adjustment.

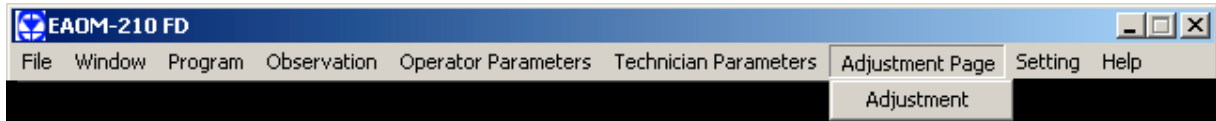

Adjustment (Calibration):

Click "Adjustment" in Adjustment Page menu. Then Technician Password is monitored. Enter the Technician Password and click OK button. If the password is correct, the ADJUSTMENT section will be viewed.

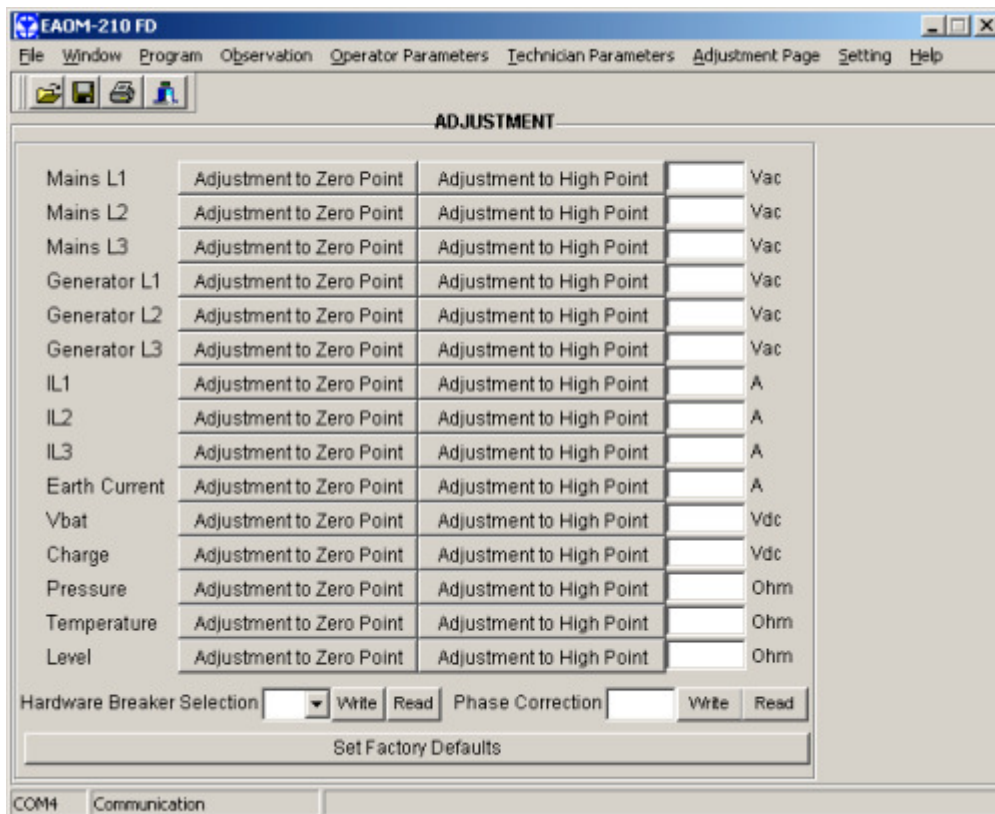
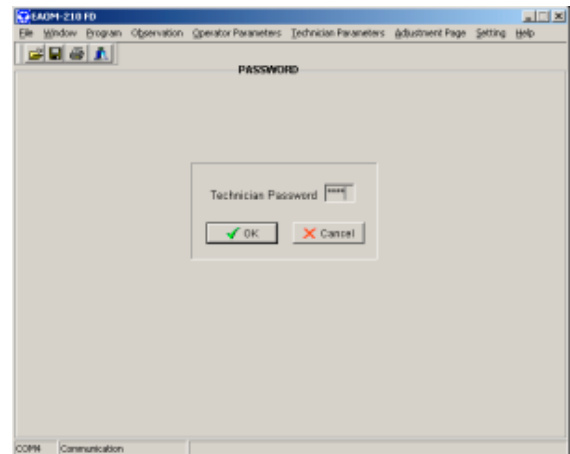
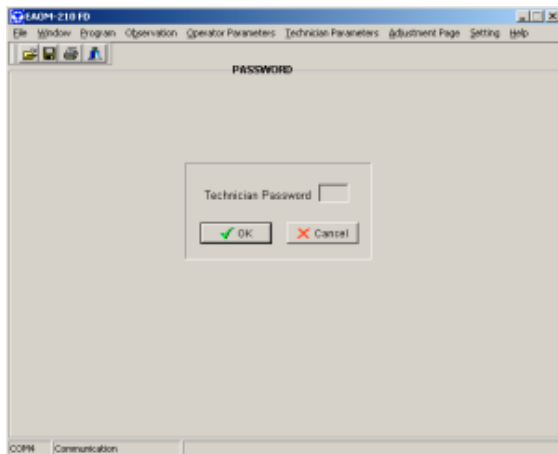

Setting Menu

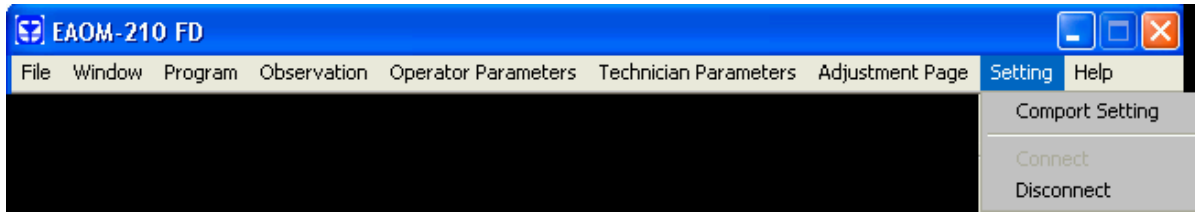

Comport Setting: Click “Comport Setting” in Setting menu. Then Comport Settings window is monitored. And then change Comport Settings, Slave ID parameters and click OK button.

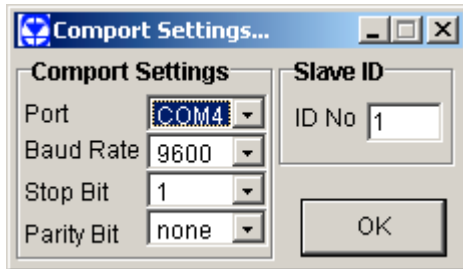

Connect: With this menu, the window below is observed. According to the ‘Connect with Modem’ check status, connection can be establish over RS-232 port or modem. If the comport settings are done correctly, when the ‘Connect’ button is pressed, connection is established.

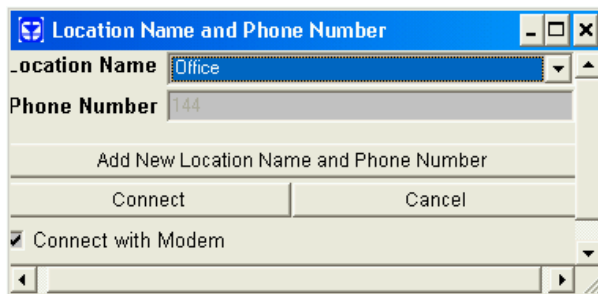

Disconnect: If the connection is established over modem or RS-232 port, connection can be cut off with this selection.

Help Menu

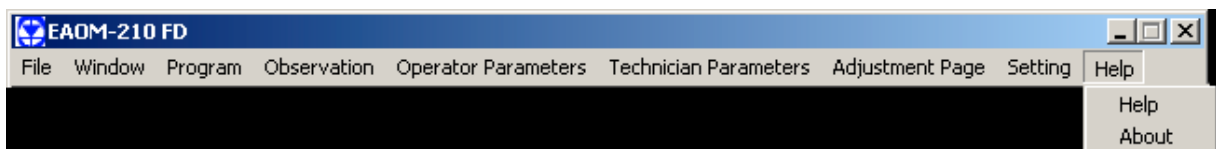

Help: This menu allows the user to get information about mention to used the program and the menus in the program.

About: Click “About” in Help menu. Then About window is monitored.

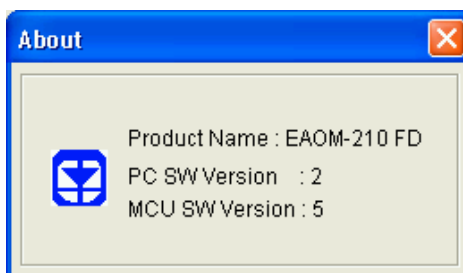

Section 4 Commissioning

These commissioning checks may interfere with the power supply to the load. Therefore they should not be carried out with a mission-critical load connected to the system.

4.1 Manual operation

1. Check that the unit is correctly wired and that the wiring is of a standard and rating compatible with the system.
 2. Check that the correct fuses are fitted.
 3. Program the unit as detailed in *Section 3 Definition Of Front Panel And Programming.*
 4. Take temporary steps to prevent the engine from starting . (for example, disable the fuel solenoid.)
 5. After a visual inspection to ensure it is safe to proceed, connect the battery supply.
 6. On the EAOM-210 FD, press the **Man** (33) button. The associated LED (14) should light.
 7. Press the **Engine Start** (21) button. At this moment the LED (8) lights on.
 8. Check that the engine start sequence commences. The starter motor should run for the programmed time period (cranking time) for the pre-set number of times (number of start attempts).
 9. Check that the **Failed to Start** LED flashes and the LED (8) lights off.
 10. Check the unit will change to the OFF mode and the LED (11) lights on.
 11. Restore the engine to operational state (reconnect the fuel solenoid).
 12. Press the **Man** (33) button. The LED (14) will light on.
 13. Press the **Engine Start** (21) button. The LED (8) will light on.
 14. Check the start sequence, as follows:
 - the starter motor runs
 - the engine starts
 - the starter motor disengages once the engine is running.
- If not, check that the engine is fully operational (fuel available etc.) and check the wiring and programming of the EAOM-210 FD.
15. Check that the engine runs up to its operating speed. If not and an alarm is present, check that the alarm is valid and then check the input wiring.
 16. Press the **Engine Stop** (22) button. At this moment the LED (9) will light on. The engine should stop. Allow time for the engine to come to rest.

4.2 Auto Operation

1. Check that the mains is connected to the unit and is present.
2. Check the mains voltage readings on the display.
3. At the EAOM-210 FD, press the **Auto** (31) button. The LED (12) on the button should light.
4. Switch off the mains supply to the unit. Check that the generator starts and, after a delay, the load is transferred to the generator.
5. Restore the mains supply to the unit. Check that, after a delay, the load is transferred back to the mains and the generator, after a further delay, shuts down.

4.3 Test Mode Operation

1. Check that the mains is connected to the unit.
2. Press the **Test** (32) button. At this moment the LED (13) will light on.
3. Check that the generator starts and that the load is still connected to the mains.
4. Switch off the mains supply. Check that the contactors change over to connect the load to the generator. Check also that the **Auto** (12) LED is lit. The unit changes operating mode to AUTO Mode automatically.
5. Restore the mains supply. Check that the contactors reconnect the load to the mains supply.
6. Check that the generator shuts down with cool-down period.

Section 5 Operation

5.1 Controls and Indicators

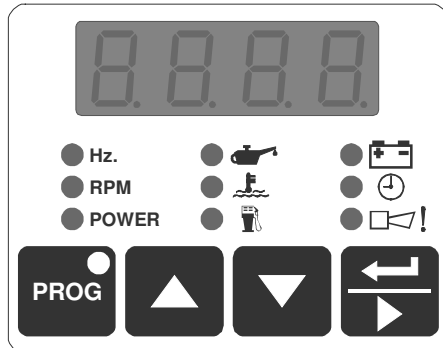

5.1.1 Alternate Display Description



Four-digit, seven-segment LED display. This multi-function display the selected parameter from the list alongside. Use the  (Display Scroll) button to select which parameter is to be displayed, as indicated by the adjacent LEDs. The button selects the parameters in sequence, as follows.

- Generator Hz (if enabled)
- Mains Hz
- Engine Rpm (if enabled)
- Generator kVA
- Generator kW
- Generator kVAr
- Engine Oil pressure (if enabled)
- Coolant temperature (if enabled)
- Fuel Level
- Battery voltage
- Charge generator voltage
- Real Time. Year, Month, day, hour, minute.

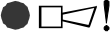

- Engine run time. Engine running time in hours. This is a six-digit number. The first three (high) digits are shown in the first display - prefixed *H* - and the second three digits are shown in the second (low) display - prefixed *L*.

-  LED will flash continually if the unit detects any fault. When the  (Display Scroll) button is pressed so as to select this option, the display will show the cause of the fault indication. If more than one error condition is present, repeated pressing of the button will show each in turn. Possible error messages are:

Bt.EH : Battery High Error.
Bt.EL : Battery Low Error.
EF.Er : Earth Fault Error
EF.tr : Earth Fault Electrical Trip
EF.ur : Earth Fault Warning
EnG.F : Multiple engage fail
E.StP : Emergency Stop.

GB.CA : Generator Breaker Not Closed alarm
GB.OA : Generator Breaker Not Opened alarm
GOF.P : Generator Over Frequency Prealarm
GOV.P : Generator Over Voltage Prealarm
GUF.P : Generator Under Frequency Prealarm
GUV.P : Generator Under Voltage Prealarm
LVL.E : Fuel Level Error.
LVL.P : Fuel Level Prealarm.
M.Er : Maintenance error
MB.CA : Mains Breaker Not Closed alarm
MB.OA : Mains Breaker Not Opened alarm
OC.Er : Over Current Error
OC.tr : Over Current Electrical Trip
OC.ur : Over Current Warning
OSP.E : Over speed error
OSP.P : Over speed pre-alarm
PrS.P : Oil Pressure Prealarm.
RP.Er : Reverse Power Error
RP.ur : Reverse Power Warning
RP.tr : Reverse Power Electrical Trip
SC.Er : Short Circuit Error
SC.tr : Short Circuit Electrical Trip
SC.ur : Short Circuit Warning
SP4.E : Spare 4 Error.
SP5.E : Spare 5 Error.
SP6.E : Spare 6 Error.
SPE.L : Speed loss error
StP.E : Generator Stop Error.
TP.PA : Generator Temperature Prealarm.
USP.E : Under speed error
USP.P : Under speed pre-alarm

The  ! LED will be skipped if there are no faults.

- Event messages. When The **Eunt** message is displayed, Events (from 1 to 32) can be displayed sequentially with the  and  buttons. Possible Event messages are:

EV.01: generator low voltage pre-alarm
EV.02: generator low voltage shutdown
EV.03: generator high voltage pre-alarm
EV.04: generator high voltage shutdown
EV.05: generator low frequency pre-alarm
EV.06: generator low frequency shutdown
EV.07: generator high frequency pre-alarm
EV.08: generator high frequency shutdown
EV.09: generator low speed pre-alarm
EV.10: generator low speed shutdown
EV.11: generator high speed pre-alarm
EV.12: generator high speed shutdown
EV.13: generator maintenance error
EV.14: generator maintenance warning
EV.15: charge alternator fail

EV.16: generator fail to start
EV.17: generator fail to stop
EV.18: battery low voltage alarm
EV.19: battery high voltage alarm
EV.20: high temperature pre-alarm
EV.21: high temperature shutdown
EV.22: oil pressure pre-alarm
EV.23: oil pressure shutdown
EV.24: fuel level pre-alarm
EV.25: fuel level alarm
EV.26: emergency stop error
EV.27: spare 1 error
EV.28: spare 2 error
EV.29: spare 3 error
EV.30: spare 4 error
EV.31: spare 5 error
EV.32: spare 6 error
EV.33: mains breaker close error
EV.34: mains breaker open error
EV.35: gen breaker close error
EV.36: gen breaker open error
EV.37: over current alarm
EV.38: short circuit alarm
EV.39: earth fault alarm
EV.40: reverse power alarm
EV.41: magnetic pickup loss of speed error
EV.46: changed mode to off
EV.47: changed mode to manual
EV.48: changed mode to test
EV.49: changed mode to auto

Example-1: Using Alternate Display.

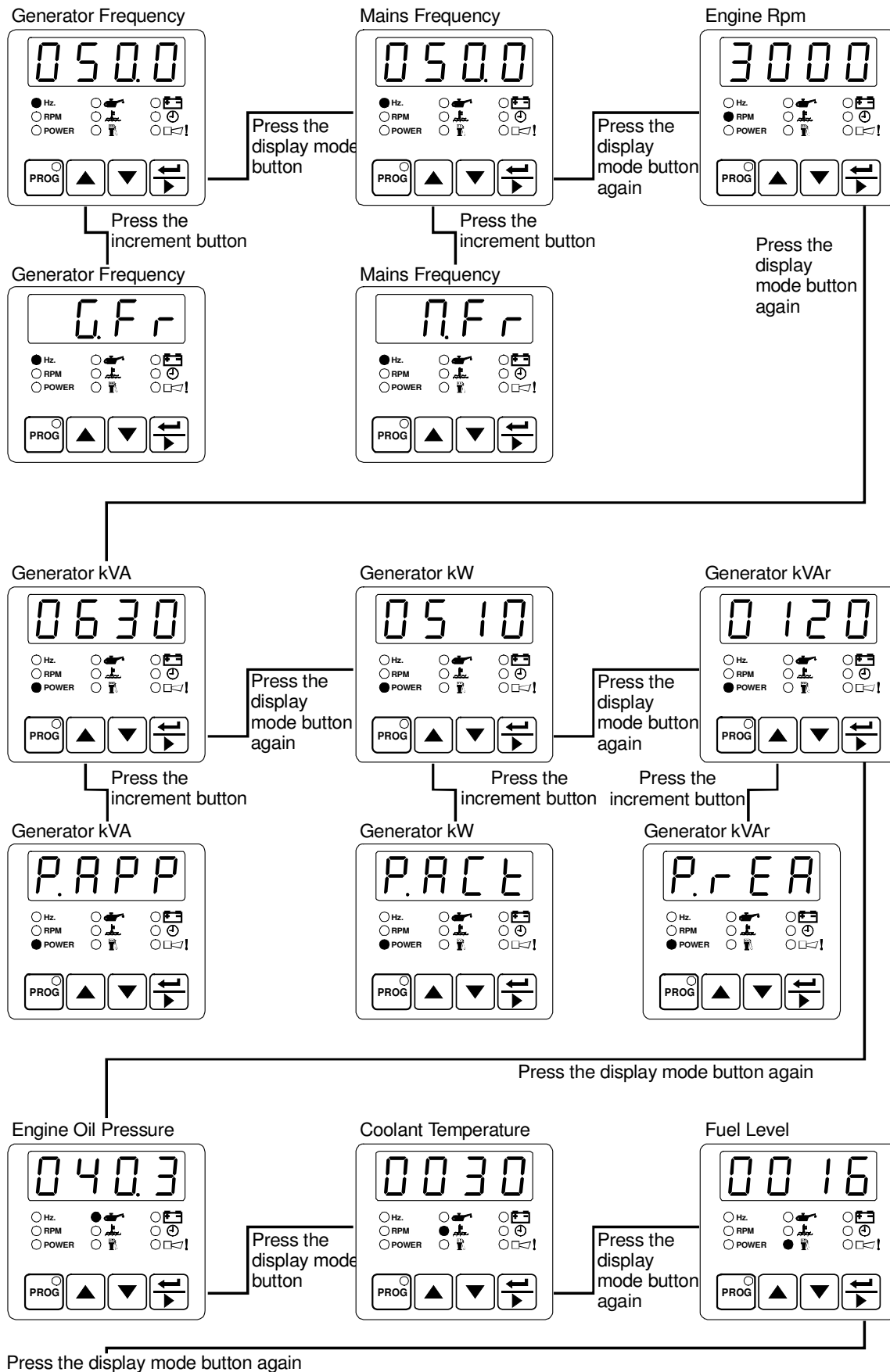

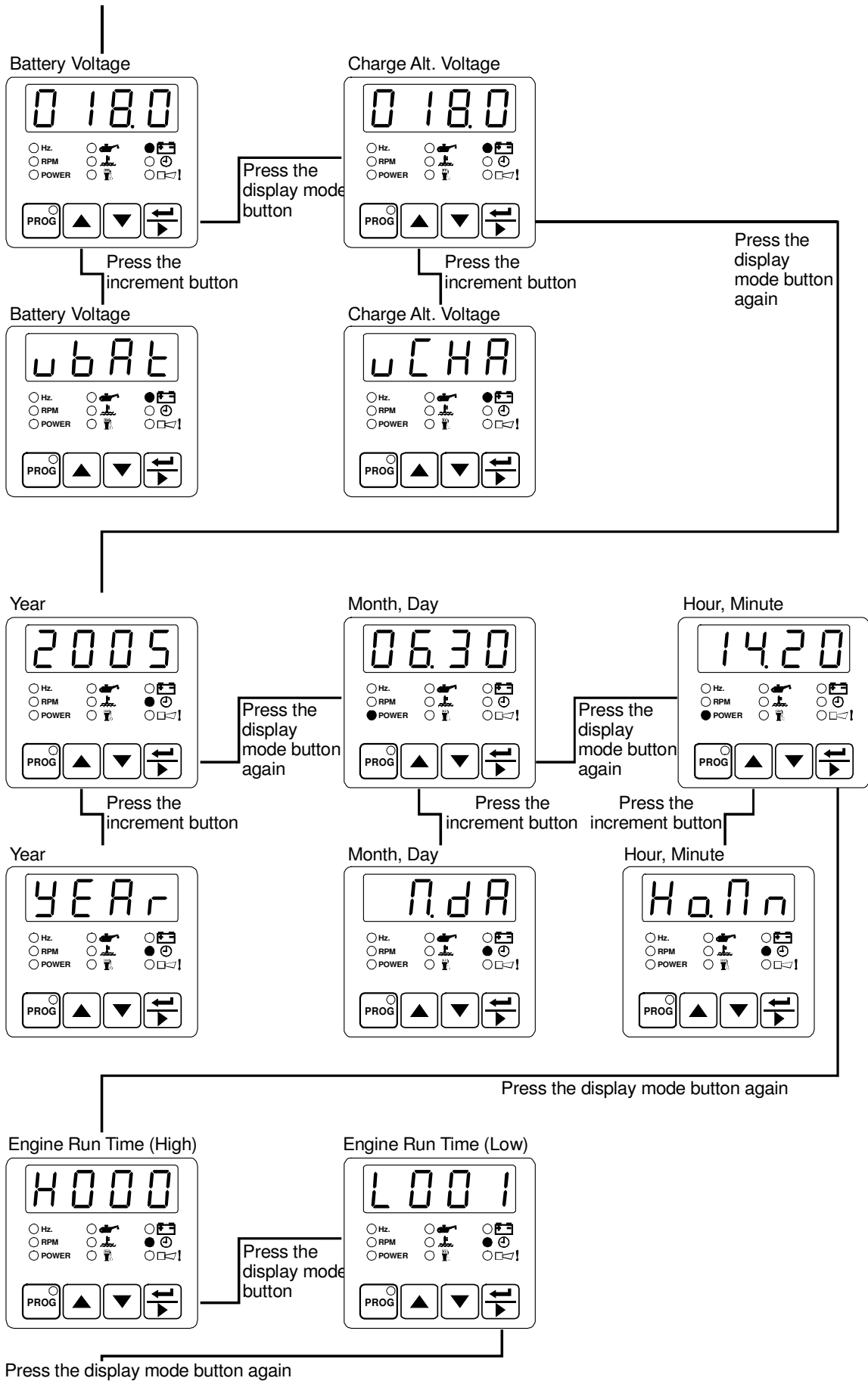

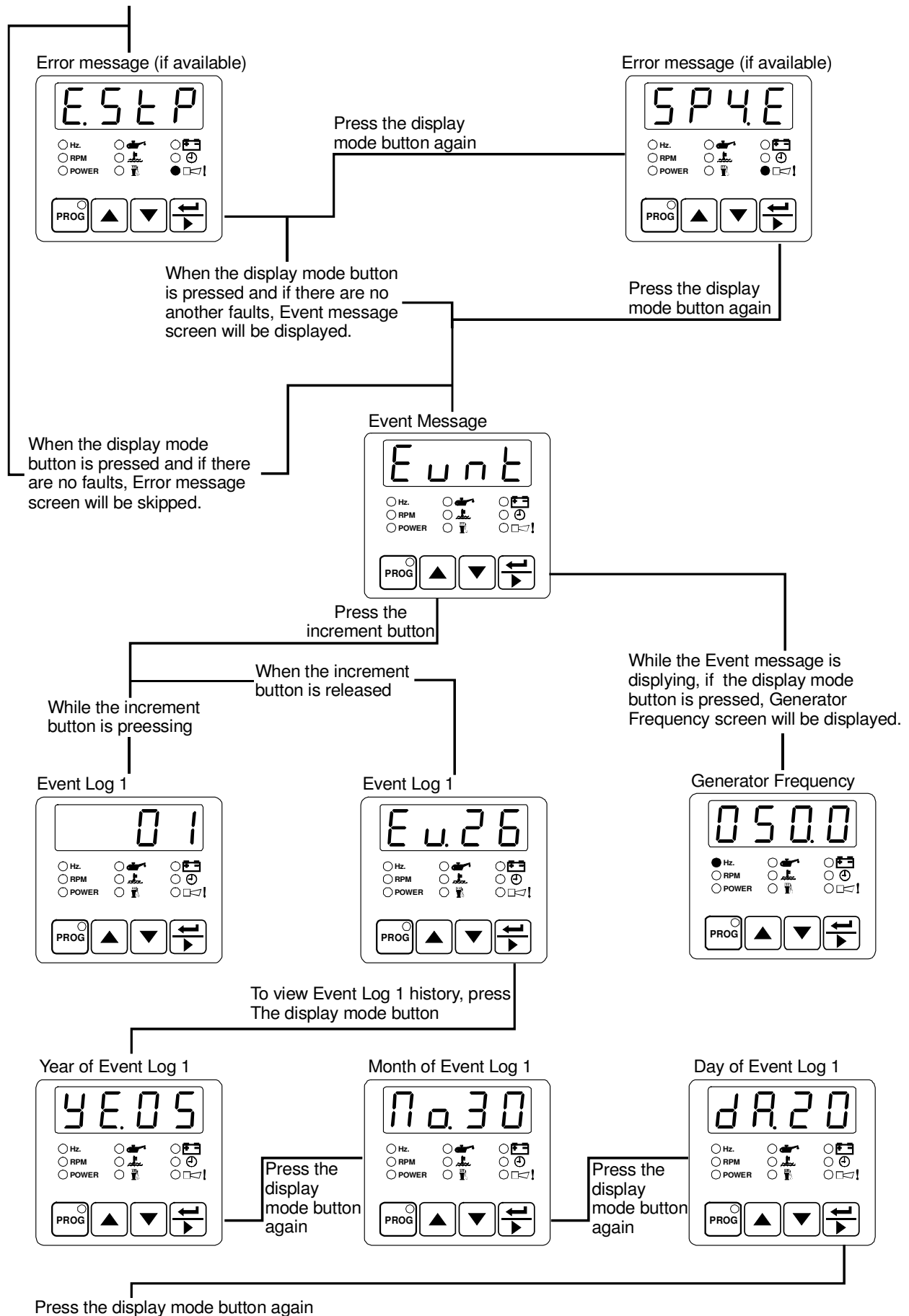

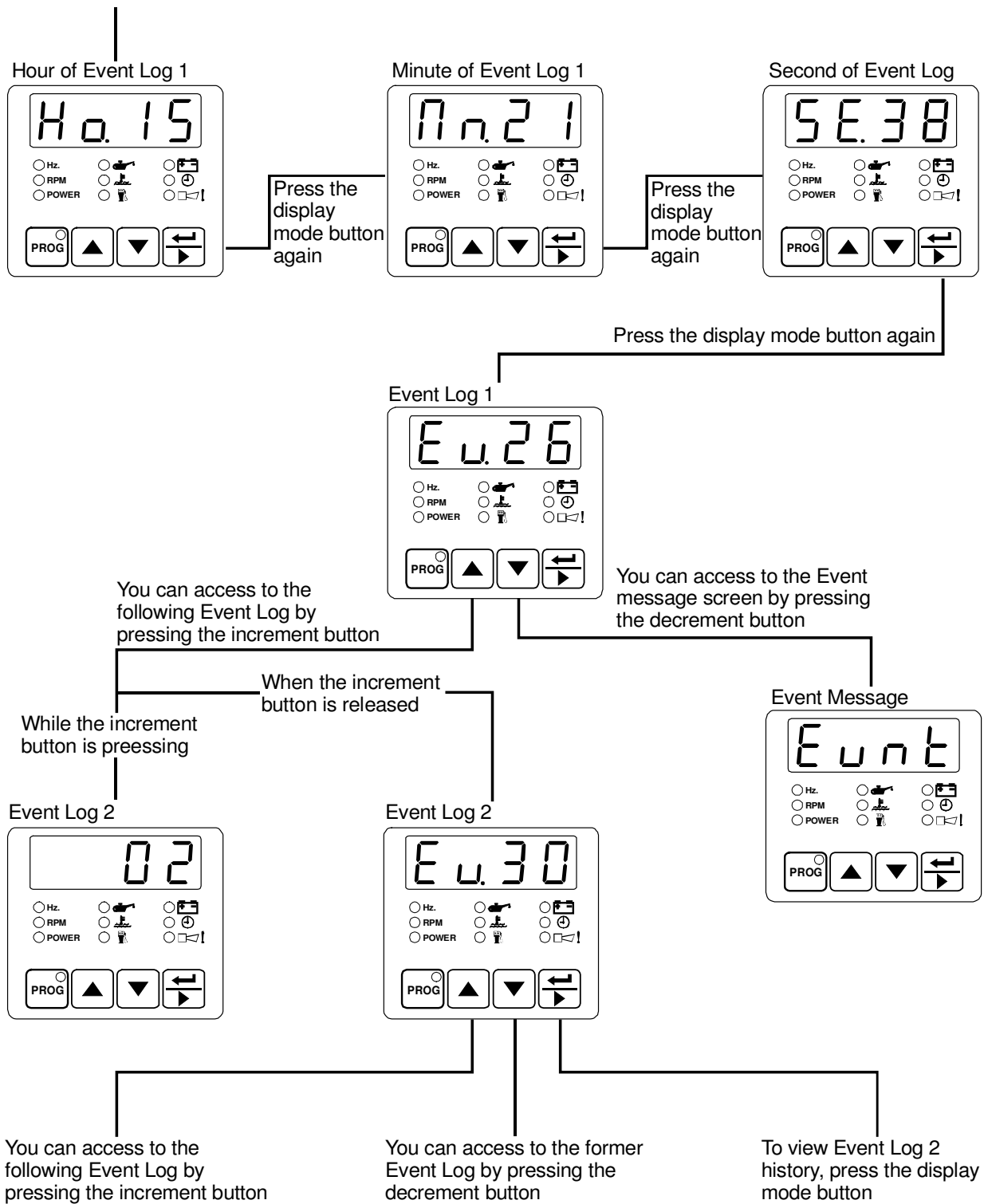

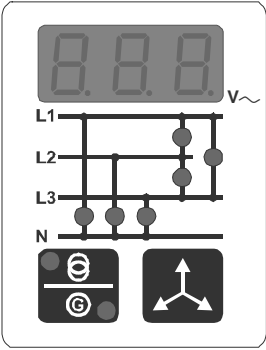

5.1.2 Voltage Display Description



Three-digit, seven-segment LED display. This display the selected parameter from the list underside. Use the  button to select which voltage mains or generator is to be displayed. The  button selects the voltage in sequence, as follows.

- Mains or Generator voltage L1-N
- Mains or Generator voltage L2-N
- Mains or Generator voltage L3-N
- Mains or Generator voltage L1-L2
- Mains or Generator voltage L2-L3
- Mains or Generator voltage L3-L1

Example-1: Using Voltage Display with single phase selection.

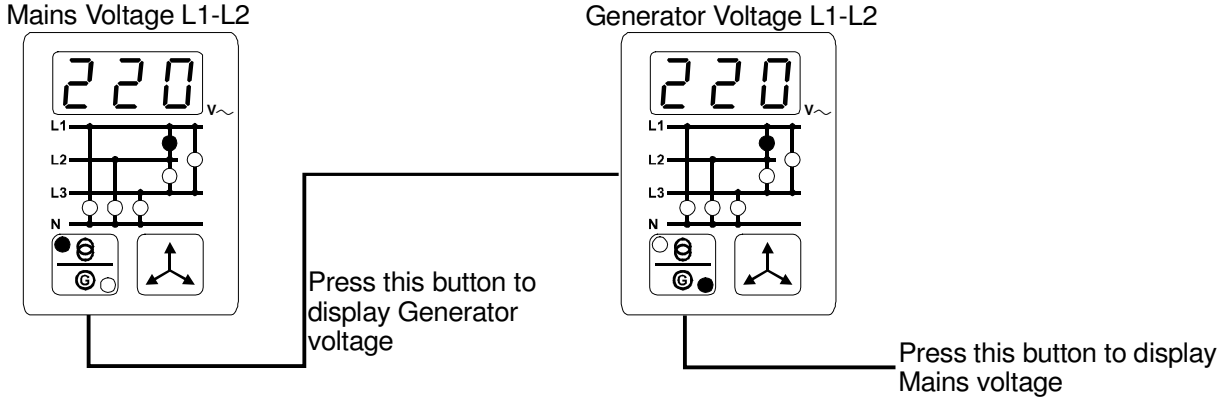

Example-2: Using Voltage Display with three phase selection.

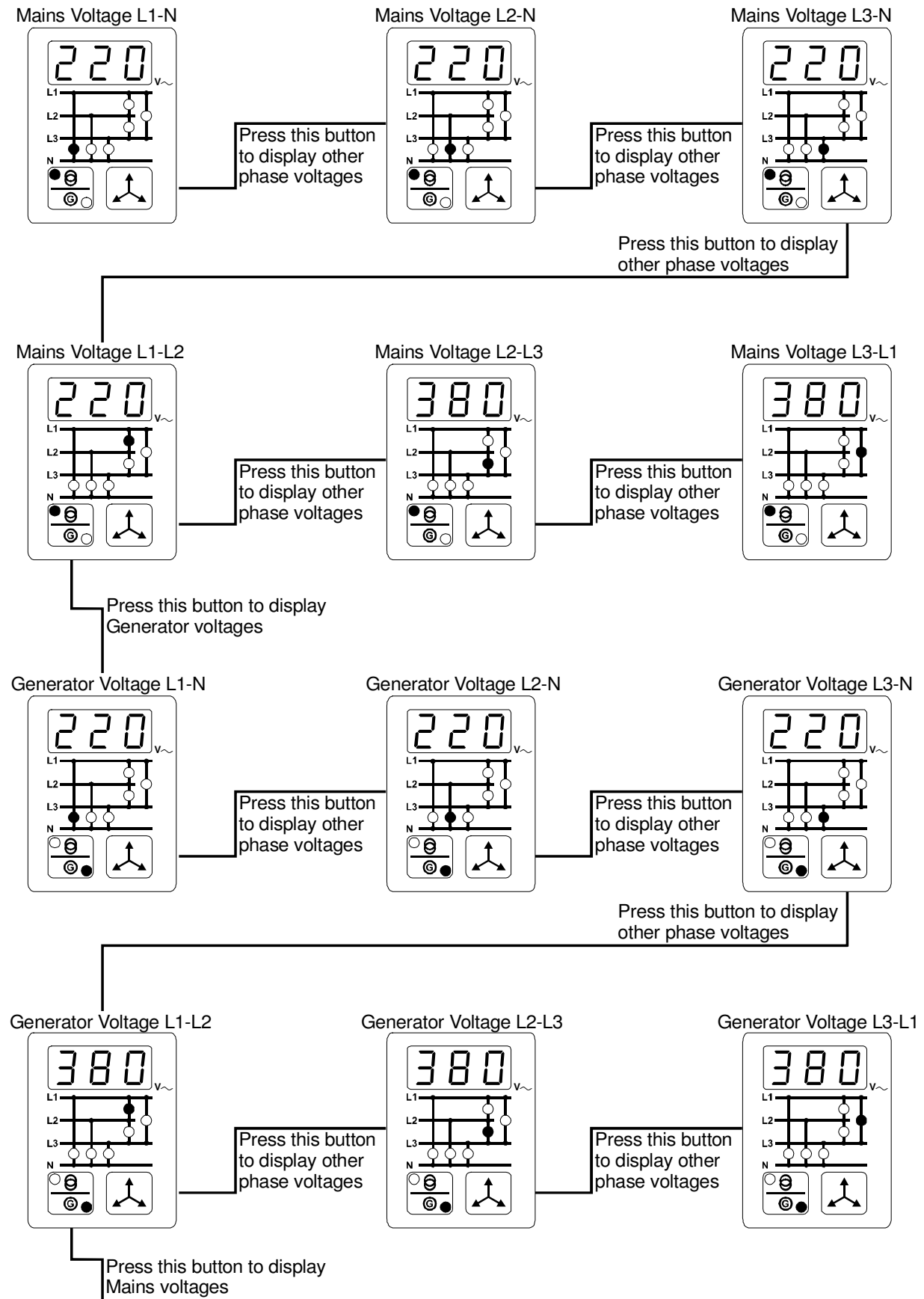

5.1.3 Current Display Description

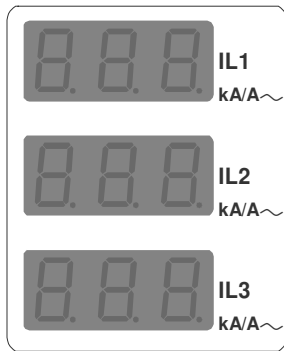

Three-digit, seven-segment LED displays. These displays, including:

- Load Amps (IL1, IL2, IL3)
- Load earth current (IE)
- Generator kVAh
- Generator kWh
- Generator kVArh
- Generator pf

Example-1: Displaying Load Amps (IL1, IL2, IL3).

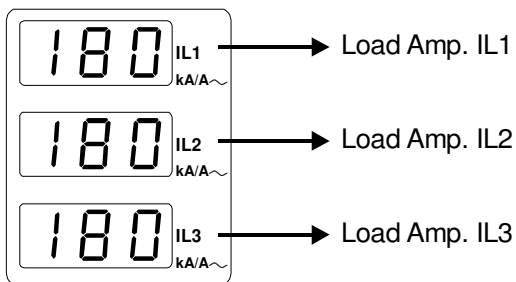

Example-2: Displaying Earth Current (IEA).

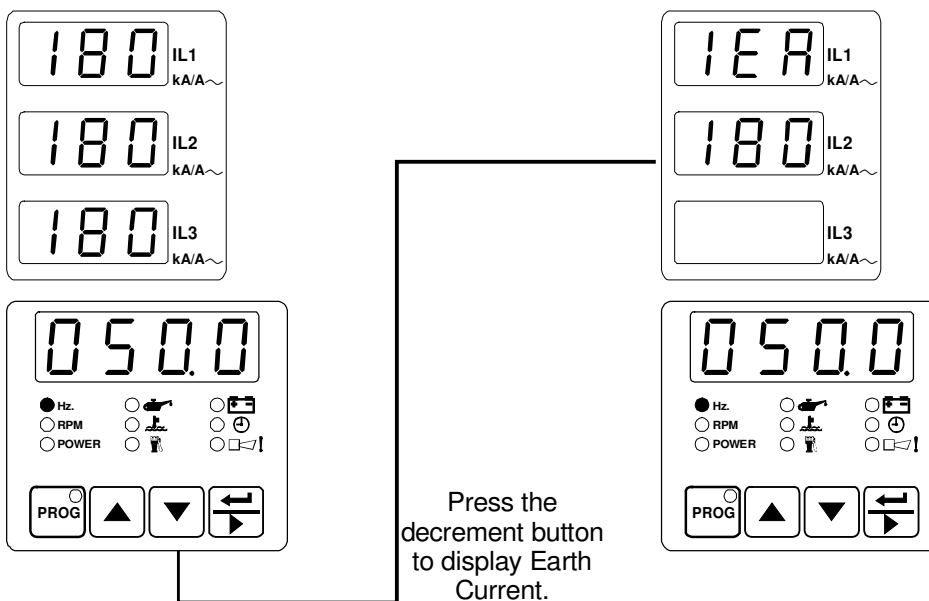

Example-3: Displaying Generator kVAh.

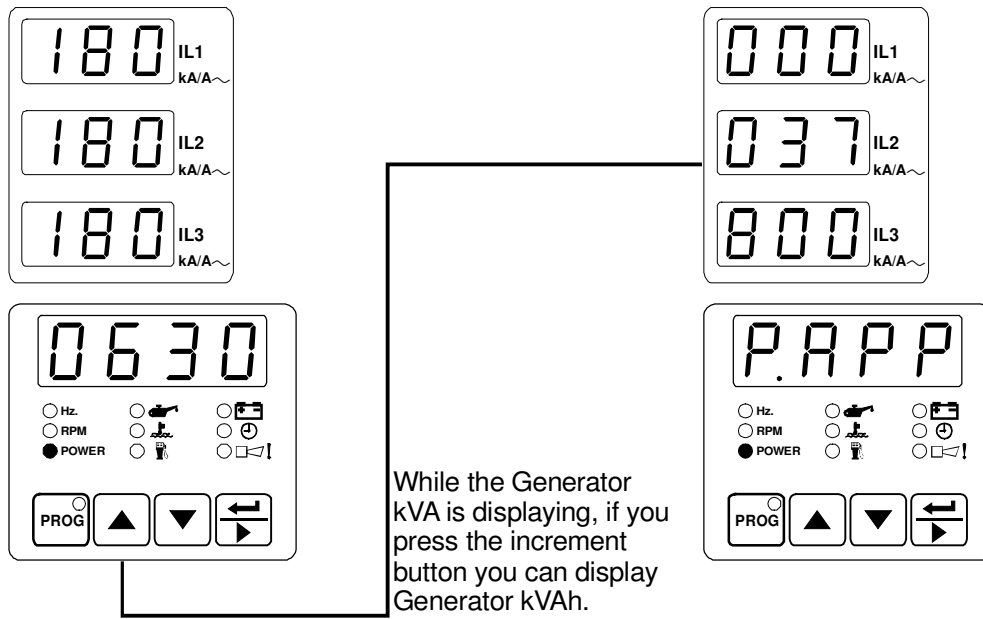

Example-4: Displaying Generator kWh.

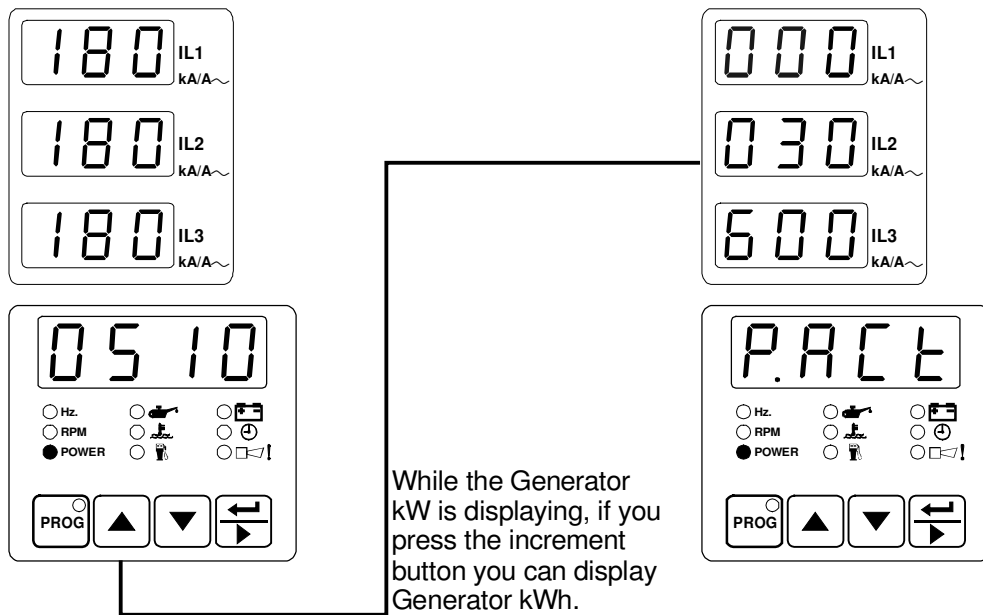

Example-5: Displaying Generator kVArh.

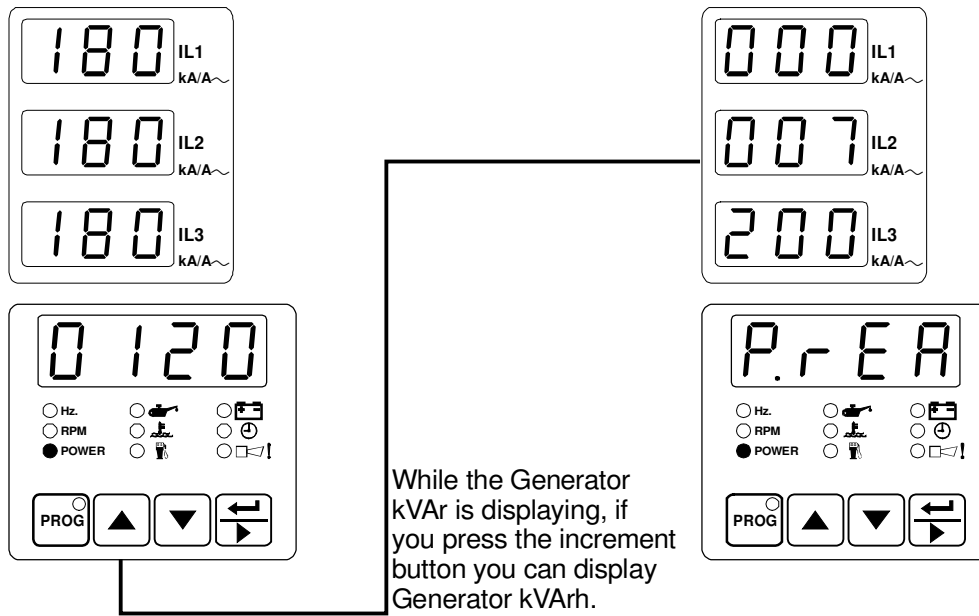

Example-6: Displaying Generator pf.

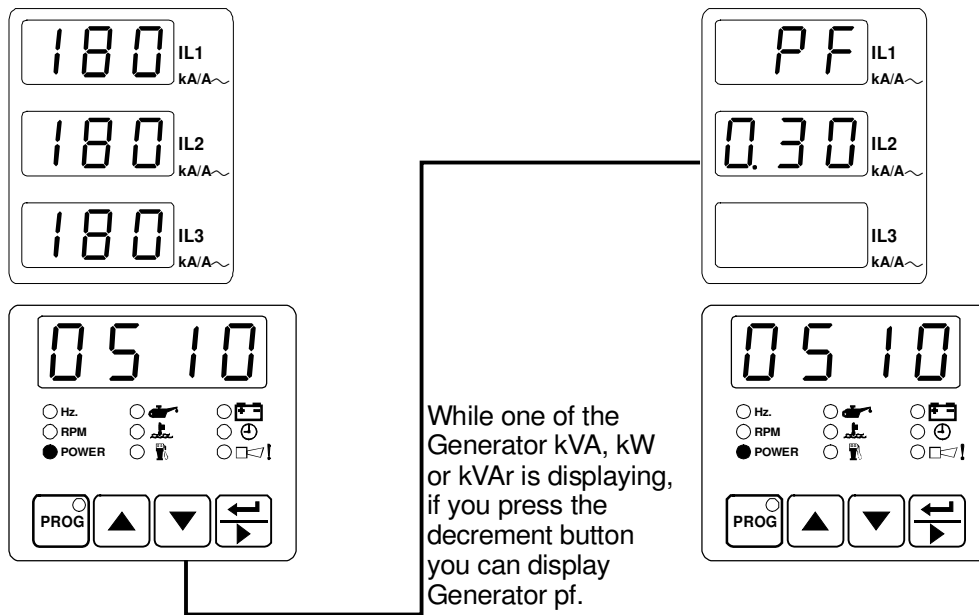

5.1.4 Failure Indicators Description

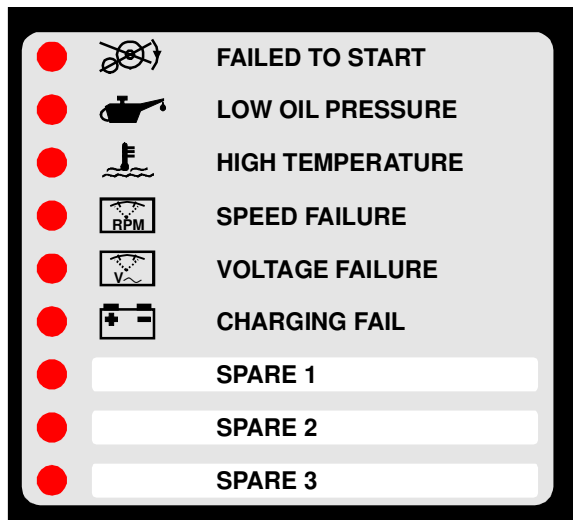

Explanations:

- 1- **Failed to Start LED** : This LED flashes if the engine has not started after the programmed number of attempts. The unit must be reset, by pressing the Reset button, before a fresh attempt can be made.
- 2- **Low Oil Pressure Failure LED** : This LED flashes if the Oil Pressure Sender and the Low Oil Pressure Input (if conf. input-1 is selected as Low Oil pressure) on the engine indicate low oil pressure while the engine is running. If this fault occurs, the unit will stop the engine without any cool-down period.
- 3- **High Temperature Failure LED** : This LED flashes if the Temperature Sender and the High Temperature Input (if conf. input-2 is selected as High Temperature) on the engine indicates high temperature while the engine is running. If this fault occurs, the unit will stop the engine without any cool-down period.
- 4- **Over Speed Failure LED** : This LED flashes if the Alternator Frequency goes below the Generator Under Frequency parameter or above the Generator Over Frequency parameter. For a fault to be indicated, the speed must be outside these limits for longer than the period defined by the Generator Frequency Error Control Time parameter. This failure immediately stops the generating set, without any cool-down period.
- 5- **Voltage Failure LED** : This LED flashes if the Alternator output voltage is outside of the limits programmed into Generator Under Voltage parameter, and Generator Over Voltage parameter, For a time period longer than the Generator Voltage Error Control Time parameter. This failure immediately releases the generator contactor, and stops the generating set, without any cool-down period.
- 6- **Charge Generator Failure LED** : This LED flashes if the field current for the battery charge generator fails to fall to zero after the engine has started. A fault will not be indicated if the current falls within the period defined by the Safety On Delay parameter after the engine has started. This failure will not stop the generating set.
- 7- **Configurable Input-1 LED (SPARE 1)**: This LED indicate the status of the input Pin 21, and the controller can be programmed to perform 24 different functions when this input is asserted.

-
- 8- **Configurable Input-2 LED (SPARE 2):** This LED indicate the status of the input Pin 20, and the controller can be programmed to perform 24 different functions when this input is asserted.
 - 9- **Configurable Input-3 LED (SPARE 3):** This LED indicate the status of the input Pin 19, and the controller can be programmed to perform 24 different functions when this input is asserted.

5.2 Mode transition

The mode can be changed at any time. A change in mode will not effect the current state of the generator or load connection. For example; if the unit is in Auto mode with the generator running and the load running on the generator, changing the mode to Manual will not effect the operating state. Any changes between Auto, Manual and Test modes will not change the operating state.

5.3 Manual Start

1. Press the **Man** (33) button. The LED (14) will light on.
2. Press the **Engine Start** (21) button on the panel the LED (8) will light on. The engine should start. The sequence is as follows:
 - The starter motor runs
 - The engine starts

Once the engine is running,

- The LED (7) “Engine Running” is lit.
 - The “Generator Ready” LED (6) is lit after “safety on delay” time period like as AUTO mode.
 - It is not possible supply to load on the generator unless “Generator Ready” LED (6) is lit. (The contactor open / close button does not work)
3. Once LEDs have lit, press the Mains contactor open button (18) to disconnect the load from the mains supply. LED (4) should go off.
 4. Press the Generator contactor close button (19) to connect the load to the generator supply. LED (5) should light.

5.4 Manual Stop

The LED (9) is lit and engine is stopped when the “Engine Stop” (22) button is pressed. When the “Engine Stop” button is pressed while the load connected to the alternator output (generator output) first alternator contactor is released then engine is stopped.

5.5 Auto Operation

Press the **Auto** (31) button to select Auto mode. The LED (12) in the corner of the button will light to indicate this mode has been selected.

In the event of a mains voltage failure, the unit will start up the generator and, once the generator is running and alternator voltage available, will transfer the load to the generator. When the mains is restored and stable, it will transfer the load back to the mains and, after a cool-down period, shut down the generator.

5.6 Test Operation

Press the **Test** (32) button to select Test mode the LED (13) will light on. This mode allows for testing of the generator off load. All alarm circuits will operate so that any faults will be reported. If a mains failure occurs while the unit is in Test mode, the unit will revert to Auto mode and will switch the load to the generator.

5.6.1 Exercise Function

Please enter the days of the weekly workdays for Exercise Function. Example:

E1 C	(dis)0	The exercise function is Mondays disabled.
	(10)	The exercise function is every Monday enabled for 10 minutes.
E1Hm	12.20	The exercise function is every Monday started at 12.20 o'clock (if it is enabled)

When the Real-Time clock reached to the Generator Exercise Work Start Time (12.20 o'clock) if the unit is in "AUTO MODE" and Mains is available the unit changes running mode to the "TEST MODE" automatically and starts the engine. The time period of engine running is counted and compared with value of Generator Exercise Working Time parameter (10 minutes). (If the engine does not run time is not counted). If the time is completed the unit changes run mode to "AUTO" automatically. When the unit is in the "TEST MODE" if the Mains is gone, the unit will change run mode to "AUTO MODE" automatically.





Section 6 Fault Finding

6.1 General

Indicators on the central section of the panel will flash if a fault is detected. For details *see Section 5.1.4 Failure Indicators Description*. Fault conditions latch so that further operation is prevented. If a failure is indicated, proceed as follows:

1. Find and fix the fault.
2. Press the **Failure Reset (29)** button to enable a restart.
3. Select the required mode of operation - Manual, Auto or Test.

6.2 Error Messages

In addition to the indicators on the centre panel, the  LED will flash in the event of a fault. To discover the fault being reported by the  LED, press repeatedly  (Display Scroll) button until this option has been selected. The display will indicate the fault condition, as follows. If there is more than one fault message, repeated pressing of the  (Display Scroll) button will show each in turn. If there are no fault messages, the this option will be skipped. Error Messages are:

- Bt.EH** : This message indicates that a battery high voltage alarm has occurred.
- Bt.EL** : This message indicates that a battery low voltage alarm has occurred.
- EF.Er** : This message indicates that a earth fault shutdown has occurred.
- EF.tr** : This message indicates that a earth fault electrical trip has occurred.
- EF.ur** : This message indicates that a earth fault warning (pre-alarm) has occurred.
- EnG.F** : This message indicates that the multiple engage fail has occurred.
- E.StP** : This message indicates that an emergency stop alarm has occurred.
- GB.CA** : This message indicates that a generator breaker not closed alarm has occurred.
- GB.OA** : This message indicates that a generator breaker not opened alarm has occurred.
- GOF.P** : This message indicates that a generator over frequency warning (pre-alarm) has occurred.
- GOV.P** : This message indicates that a generator over voltage warning (pre-alarm) has occurred.
- GUF.P** : This message indicates that a generator under frequency warning (pre-alarm) has occurred.
- GUV.P** : This message indicates that a generator under voltage warning (pre-alarm) has occurred.
- LVL.E** : This message indicates that the fuel level shutdown has occurred.
- LVL.P** : This message indicates that the fuel level warning (pre-alarm) has occurred.
- M.Er** : This message indicates that the generator is now due for maintenance.
- MB.CA** : This message indicates that a mains breaker not closed alarm has occurred.
- MB.OA** : This message indicates that a mains breaker not opened alarm has occurred.
- OC.Er** : This message indicates that a over current shutdown has occurred.
- OC.tr** : This message indicates that a over current electrical trip has occurred.
- OC.ur** : This message indicates that a over current warning (pre-alarm) has occurred.

OSP.E : This message indicates that the over speed shutdown has occurred.
OSP.P : This message indicates that the over speed warning (pre-alarm) has occurred.
PrS.P : This message indicates that a low oil pressure warning (pre-alarm) has occurred.
RP.Er : This message indicates that a reverse power shutdown has occurred.
RP.ur : This message indicates that a reverse power warning (pre-alarm) has occurred.
RP.tr : This message indicates that a reverse power electrical trip has occurred.
SC.Er : This message indicates that a short circuit shutdown has occurred.
SC.tr : This message indicates that a short circuit electrical trip has occurred.
SC.ur : This message indicates that a short circuit warning (pre-alarm) has occurred.
SP4.E : This message indicates that a spare 4 alarm has occurred.
SP5.E : This message indicates that a spare 5 alarm has occurred.
SP6.E : This message indicates that a spare 6 alarm has occurred.
SPE.L : This message indicates that the magnetic pick-up sensor fail (speed loss error) has occurred.
StP.E : This message indicates that the generator has failed to stop within the selected time.
TP.PA : This message indicates that a high engine coolant temperature warning (pre-alarm) has occurred.
USP.E : This message indicates that the under speed shutdown has occurred.
USP.P : This message indicates that the under speed warning (pre-alarm) has occurred.

Table 6.1 Fault finding

Symptom	Possible remedy
Unit is inoperative.	Check the battery and wiring to the unit.
	Check the DC supply. (measure voltage between pins 39 and 40)
	Check the DC fuse.
Low oil pressure fault operates after engine has started.	Check engine oil level and pressure.
	Check oil pressure switch and sender and wiring.
	Check configured polarity (if applicable) is correct (i.e. Normally Open or Normally Closed) or that sender is compatible with the device.
High engine temperature Fault operates after engine has started.	Check engine temperature.
	Check temperature switch and sender and wiring.
	Check configured polarity (if applicable) is correct (i.e. Normally Open or Normally Closed) or that sender is compatible with the device.
Shutdown fault operates.	Check relevant switch and wiring of fault indicated on the panel.
	Check configuration of input.
Warning fault operates.	Check relevant switch and wiring of fault indicated on the panel.
	Check configuration of input.
Failed to Start fault. Engine failed to start after Pre-set number of Attempts.	Check fuel solenoid and wiring, fuel and battery. Reset the EAOM-210 FD and restart the engine.
	Check the signals that the EAOM-210 FD is using to determine if the engine has started. Refer to engine manual.
Starter motor inoperative.	Check wiring to starter solenoid.
	Check battery supply.
	Check battery supply is present on the Start output pin 33 of the EAOM-210 FD.



Disconnect the equipment totally from electricity in the best and correct way during mechanical and electrical maintenance. When this is not possible, the equipment must be in the "OFF" position for preventing any accident.

Section 7 Specifications & Ratings

Specification:	Description:
Equipment use	Electrical control equipment for generating sets
Housing & Mounting	144 mm x 204 mm x 37 mm. (including connectors) plastic housing for panel mounting.
Panel Cut-Out	138 mm x 186 mm.
Protection	IP54 at front panel, IP20 at rear side.
Weight	Approximately 0,72 Kg.
Environmental rating	Standard, indoor at an altitude of less then 2000 meters with non-condensing humidity.
Operating / Storage Temperature	-25 C to +70 C / -40 C to +85 C
Operating / Storage Humidity	90 % max. (non-condensing)
Installation Over Voltage Category	II Appliances, portable equipment.
Pollution Degree	II, Normal office or workplace, non conductive pollution
Mode of Operation	Continuous
EMC	EN 61000-6-4, EMC Generic Emission Standard for industrial equipment EN 61000-6-2, EMC Generic Immunity Standard for industrial equipment
Electrical Safety	EN 61010-1, Safety Requirements for electrical equipment for measurement, control and laboratory use
DC Battery Supply Voltage	8 to 32 VDC max. operating current is 290 mA.
Cranking Dropouts	Battery voltage can be "0" VDC for max. 100 ms during cranking (battery voltage should be at least nominal voltage before cranking).
Battery Voltage Measurement	8 to 32 VDC, accuracy: 1 % FS, resolution: 0,1 V
Mains Voltage Measurement	Selectable three phase or single phase, 4 wire connection for three phase, 2 wire connection for single phase gen-set. 35 to 300 VAC Ph-N, 15.6 to 99.9 Hz. Accuracy: 1 % FS, Resolution: 1 V
Mains Frequency	15.6 to 99.9 Hz (min. 35 VAC Ph-N) Accuracy: 0,25 % FS, Resolution: 0,1 Hz.
Generator Voltage Measurement	Selectable three phase or single phase, 4 wire connection for three phase, 2 wire connection for single phase gen-set. 35 to 300 VAC Ph-N, 15.6 to 99.9 Hz. Accuracy: 1 % FS, Resolution: 1 V
Generator Speed	From magnetic pick-up: 35 to 10000 Hz (4 to 35 volts peak continuously.) Accuracy: 0,25 % FS
Generator Frequency	From alternator voltage: 15.6 to 99.9 Hz (min. 35 VAC Ph-N) Accuracy: 0,25 % FS, Resolution: 0,1 Hz.
CT secondary	5A.
Charge Generator Excitation	220mA, max 4W.

Specification:	Description:
Displays	Three 3 digits,7 segments, LED displays showin: Load amps (IL1, IL2, IL3) Earth current (IEA) Generator kVAh Generator kWh Generator kVArh Generator power factor (pf)
	One 3 digits, 7 segments, LED display showin: Mains volts (L1-N, L2-N, L3-N) Mains volts (L1-L2, L2-L3, L3-L1) Generator volts (L1-N, L2-N, L3-N) Generator volts (L1-L2, L2-L3, L3-L1)
	One 4 digits, 7 segments, LED display showin: Generator Hz Mains Hz Engine Rpm Generator kVA Generator kW Generator kVAr Engine oil pressure Coolant temperature Fuel level Battery voltage Charge generator voltage Real time Engine run time Error messages Event messages Program parameters
Failure Indicators	Failed to start
	Low oil pressure
	High temperature
	Speed failure
	Voltage failure
	Charging fail
	Spare 1
Spare 2	
Spare 3	
Status indicators	OFF mode LED
	TEST mode LED
	AUTOMATIC mode LED
	MANUAL mode LED
	Engine start LED
	Engine stop LED
	Engine running
	Main voltage available LED
	Generator ready LED
Mains contactor LED	
Generator contactor LED	
Communication interface	RS 232 serial communication.

Specification:	Description:
Contact sensing inputs	Emergency stop (NC)
	Low oil pressure or configurable failure input-1 (NO or NC selectable)
	High temperature or configurable failure input-2 (NO or NC selectable)
	Configurable failure inputs-3 (NO or NC selectable)
	Configurable failure inputs-4 (NO or NC selectable)
	Configurable failure inputs-5 (NO or NC selectable)
	Configurable failure inputs-6 (NO or NC selectable)
Relay outputs	Fuel relay output. 16A at DC supply voltage
	Start relay output. 16A at DC supply voltage
	Horn or configurable relay output-1. 16A at DC supply voltage
	Mains open relay output. 5A at DC supply voltage
	Mains close relay output. 5A at DC supply voltage
	Generator open relay output. 5A at DC supply voltage
	Generator close relay output. 5A at DC supply voltage
	Configurable relay output-2. 5A at DC supply voltage
	Configurable relay output-3. 5A at DC supply voltage
	Configurable relay output-4. 5A at DC supply voltage

Section 8 Block Diagram

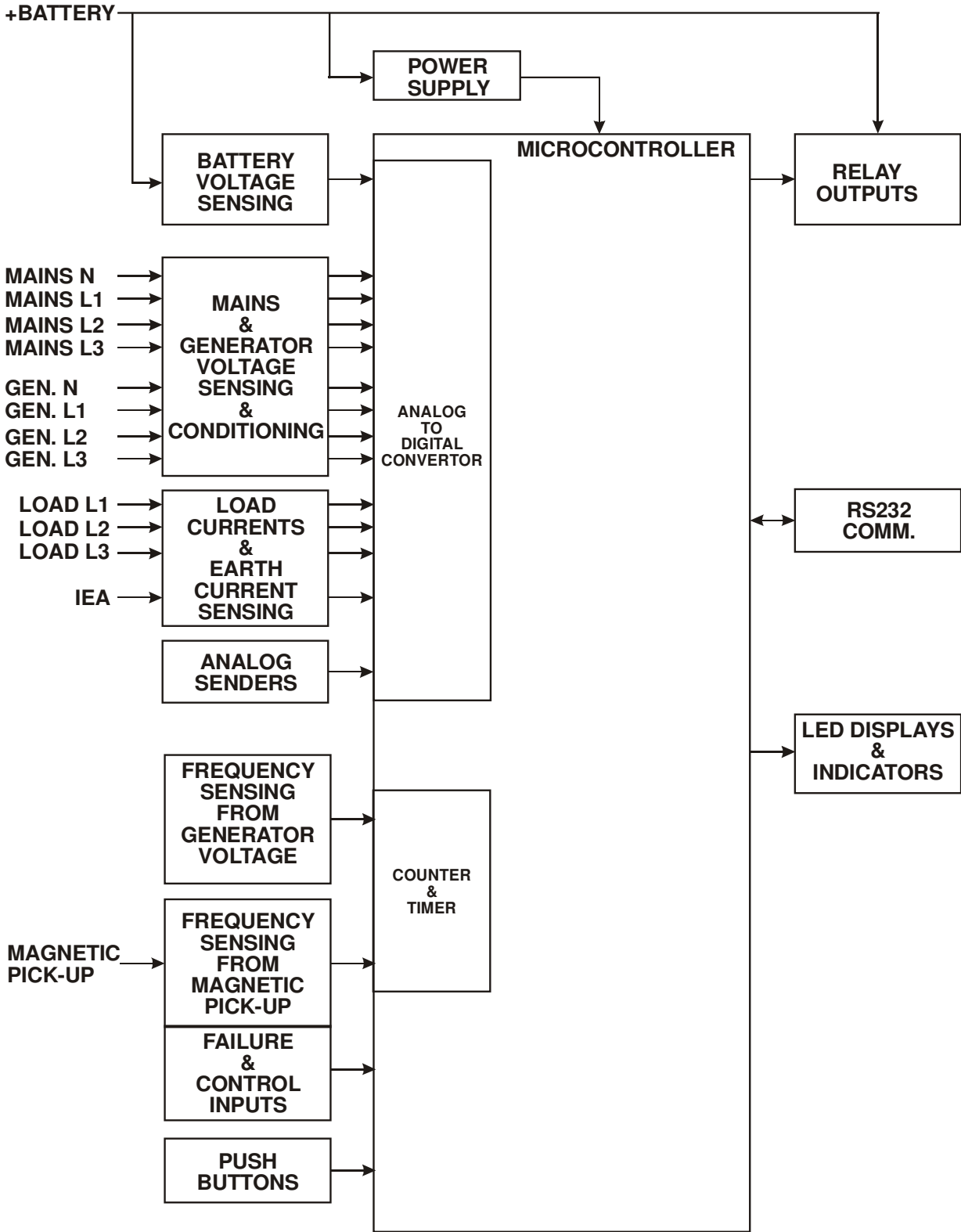

User Defined Parameter:

List-1:

	Definition of Parameter	User Defined Value
--	-------------------------	--------------------

Operator parameters

(mAL) MAINS LEVELS page		
mA1	MAINS UNDER VOLTAGE	
mA2	MAINS UNDER VOLTAGE RETURN	
mA3	MAINS OVER VOLTAGE	
mA4	MAINS OVER VOLTAGE RETURN	
mA5	MAINS UNDER FREQUENCY	
mA6	MAINS UNDER FREQUENCY RETURN	
mA7	MAINS OVER FREQUENCY	
mA8	MAINS OVER FREQUENCY RETURN	

(GnU) GENERATOR VOLTAGE LEVELS page		
GnU1	GENERATOR UNDER VOLTAGE	
GnU2	GENERATOR UNDER VOLTAGE PRE-ALARM	
GnU3	GENERATOR LOADING VOLTAGE	
GnU4	GENERATOR OVER VOLTAGE PRE-ALARM	
GnU5	GENERATOR OVER VOLTAGE PRE-ALARM RETURN	
GnU6	GENERATOR OVER VOLTAGE SHUTDOWN	

(GnF) GENERATOR FREQUENCY LEVELS page		
GnF1	GENERATOR UNDER FREQUENCY	
GnF2	GENERATOR UNDER FREQUENCY PRE-ALARM	
GnF3	GENERATOR LOADING FREQUENCY	
GnF4	GENERATOR OVER FREQUENCY PRE-ALARM	
GnF5	GENERATOR OVER FRQ PRE-ALARM RETURN	
GnF6	GENERATOR OVER FREQUENCY SHUTDOWN	

(Gno) GENERATOR CURRENT/POWER LEVELS page		
Gno1	GENERATOR OVER CURRENT	
Gno2	GENERATOR SHORT CIRCUIT	
Gno3	GENERATOR EARTH FAULT	
Gno4	MINIMUM ACTIVE POWER	

	Definition of Parameter	User Defined Value
--	-------------------------	--------------------

Technician parameters

(Gnt) GENERATOR CURRENT/POWER ACTIONS page				
Gnt0	A / KA SELECTION (0 = Ampere, 1 = KiloAmpere)			
Gnt1	CT PRIMARY			
Gnt2	CT PRIMARY (EARTH FAULT)			
Gnt3	OVER CURRENT ACTIONS -DISABLE -WARNING (ALARM ONLY, NO SHUTDOWN) -ELECTRICAL TRIP (ALARM/OFF LOAD GENERATOR FOLLOWED BY SHUTDOWN AFTER COOLING) -SHUTDOWN (ALARM AND SHUTDOWN)			
Gnt4	OVER CURRENT ALARM TIME			
Gnt5	SHORT CIRCUIT ACTIONS -DISABLE -WARNING (ALARM ONLY, NO SHUTDOWN) -ELECTRICAL TRIP (ALARM/OFF LOAD GENERATOR FOLLOWED BY SHUTDOWN AFTER COOLING) -SHUTDOWN (ALARM AND SHUTDOWN)			
Gnt6	SHORT CIRCUIT ALARM TIME			
Gnt7	EARTH FAULT ACTIONS -DISABLE -WARNING (ALARM ONLY, NO SHUTDOWN) -ELECTRICAL TRIP (ALARM/OFF LOAD GENERATOR FOLLOWED BY SHUTDOWN AFTER COOLING) -SHUTDOWN (ALARM AND SHUTDOWN)			
Gnt8	EARTH FAULT ALARM TIME	Sec	0 - 99	0
Gnt9	REVERSE POWER ACTIONS -DISABLE -WARNING (ALARM ONLY, NO SHUTDOWN) -ELECTRICAL TRIP (ALARM/OFF LOAD GENERATOR FOLLOWED BY SHUTDOWN AFTER COOLING) -SHUTDOWN (ALARM AND SHUTDOWN)	-	0-3	dis
Gnt10	REVERSE POWER ALARM TIME	Sec	0 - 99	0
Gnt11	TOTAL ENERGY CLEAR	-	No-YES	no
Gnt12	ACTIVE ENERGY CLEAR	-	No-YES	no
Gnt13	REACTIVE ENERGY CLEAR	-	No-YES	no

(GEn) MISCELLANEOUS page				
Gen1	SENSING OPTIONS GENERATOR FRQ EN/DIS			
Gen2	SENSING OPT PICKUP EN/DIS & FLYWHEEL			
Gen3	AC SYSTEM: 0= 1PHASE 2WIRE 1= 3PHASE 4WIRE 2= 3PHASE 4WIRE SERIES DELTA 3= 1PHASE 3WIRE			
Gen4	FAST LOADING FEATURE EN/DIS			
Gen5	ALL WARNINGS ARE LATCHED EN/DIS			
Gen6	MAINS FAILURE DETECTION EN/DIS			
Gen7	LOOK MAINS FAILURE FOR MAINS CONT. EN/DIS			
Gen8	ENGINE FUEL (GAS/ DIESEL) SELECTION			
Gen9	STOP / FUEL SELECTION			
Ge10	STOP SOLENOID TIME			
Ge11	IGNITION DELAY			
Ge12	GAS VALVE DELAY			
Ge13	MIN IGNITION SPEED			

	Definition of Parameter	User Defined Value
--	-------------------------	--------------------

(EnSt) ENGINE STARTING OPTIONS page		
EnS1	AUDIBLE ALARM PRIOR TO STARTING EN/DIS	
EnS2	NUMBER OF START ATTEMPTS	
EnS3	CRANKING TIME	
EnS4	CRANK REST TIME	
EnS5	MULTIPLE START ENGAGE ATTEMPTS E/D (PICK)	
EnS6	ENGAGE ATTEMPT TIME (PICKUP)	
EnS7	ENGAGE ATTEMPT REST TIME (PICKUP)	
EnS8	PICKUP SENSOR FAIL DELAY(PICKUP)	

(EnC) ENGINE CRANK DISCONNECT page		
EnC1	CRANK DISCONNECT ON GEN. FREQUENCY	
EnC2	CRANK DISCONNECT ON MAGNETIC PICKUP	
EnC3	CRANK DISCONNECT ON GEN. VOLTAGE	
EnC4	CRANK DISCONNECT ON CHARGE ALT. VOLTAGE	
EnC5	CRANK DISCONNECT ON OIL PRESSURE	

(GnS) GENERATOR SPEED SETTINGS page		
GnS1	GENERATOR UNDER SPEED	
GnS2	GENERATOR UNDER SPEED PREALARM	
GnS3	GENERATOR UNDER SPEED PREALARM RETURN	
GnS4	GENERATOR OVER SPEED PREALARM	
GnS5	GENERATOR OVER SPEED PREALARM RETURN	
GnS6	GENERATOR OVER SPEED SHUTDOWN	

(EnbA) ENGINE PLANT BATTERY page		
Enb1	BATTERY UNDERVOLTS WARNING	
Enb2	BATTERY UNDERVOLTS WARNING RETURN	
Enb3	BATT UNDERVOLTS VOLTS DELAY	
Enb4	BATTERY OVERVOLTS WARNING	
Enb5	BATTERY OVERVOLTS WARNING RETURN	
Enb6	BATT OVERVOLTS DELAY	
Enb7	CHARGE ALTERNATOR WARNING	

(Ain) ANALOGUE INPUTS page		
Ain1	OIL PRESSURE INPUT TYPE	
Ain2	OIL PRESSURE PRE-ALARM	
Ain3	OIL PRESSURE PRE-ALARM RETURN	
Ain4	OIL PRESSURE SHUTDOWN	
Ain5	TEMPERATURE INPUT TYPE	
Ain6	TEMPERATURE PRE-ALARM	
Ain7	TEMPERATURE PRE-ALARM RETURN	
Ain8	TEMPERATURE SHUTDOWN	
Ain9	LEVEL PRE-ALARM	
Ai10	LEVEL PRE-ALARM RETURN	
Ai11	LEVEL SHUTDOWN	

	Definition of Parameter	User Defined Value
--	-------------------------	--------------------

(ALin) ANALOGUE SENDER LINEARISATIONS page		
Prr0	<i>OIL PRESSURE SENDER 0</i>	
PrU0	<i>OIL PRESSURE 0</i>	
Prr1	<i>OIL PRESSURE SENDER 1</i>	
PrU1	<i>OIL PRESSURE 1</i>	
Prr2	<i>OIL PRESSURE SENDER 2</i>	
PrU2	<i>OIL PRESSURE 2</i>	
Prr3	<i>OIL PRESSURE SENDER 3</i>	
PrU3	<i>OIL PRESSURE 3</i>	
Prr4	<i>OIL PRESSURE SENDER 4</i>	
PrU4	<i>OIL PRESSURE 4</i>	
tpr0	<i>TEMPERATURE SENDER 0</i>	
tpU0	<i>TEMPERATURE 0</i>	
tpr1	<i>TEMPERATURE SENDER 1</i>	
tpU1	<i>TEMPERATURE 1</i>	
tpr2	<i>TEMPERATURE SENDER 2</i>	
tpU2	<i>TEMPERATURE 2</i>	
tpr3	<i>TEMPERATURE SENDER 3</i>	
tpU3	<i>TEMPERATURE 3</i>	
tpr4	<i>TEMPERATURE SENDER 4</i>	
tpU4	<i>TEMPERATURE 4</i>	
Ler0	<i>LEVEL SENDER 0</i>	
LeU0	<i>LEVEL 0</i>	
Ler1	<i>LEVEL SENDER 1</i>	
LeU1	<i>LEVEL 1</i>	
Ler2	<i>LEVEL SENDER 2</i>	
LeU2	<i>LEVEL 2</i>	
Ler3	<i>LEVEL SENDER 3</i>	
LeU3	<i>LEVEL 3</i>	
Ler4	<i>LEVEL SENDER 4</i>	
LeU4	<i>LEVEL 4</i>	

	Definition of Parameter	User Defined Value
(in1) DIGITAL CONFIGURABLE INPUT (1) page		
in11	<i>DISABLE, USER CONFIGURED OR SELECT FROM LIST</i>	
in12	<i>IF USER CONFIGURED -POLARITY (CLOSE TO ACTIVATE, OPEN TO ACTIVATE)</i>	
in13	<i>IF USER CONFIGURED -INDICATION (STATUS, WARNING NON-LATCHING, WARNING LATCHING, ELECTRICAL TRIP, SHUTDOWN)</i>	
in14	<i>IF USER CONFIGURED -ACTIVATION (ACTIVE FROM STARTING, ACTIVE FROM SAFETY ON, ALWAYS ACTIVE)</i>	
in15	<i>IF SELECT FROM LIST 0 REMOTE START 1 AUXILIARY MAINS FAIL 2 SIMULATE LAMP TEST BUTTON 3 SIMULATE HORN RESET BUTTON 4 SIMULATE ALARM RESET BUTTON 5 SIMULATE OFF BUTTON 6 SIMULATE AUTO BUTTON 7 SIMULATE TEST BUTTON 8 SIMULATE MANUAL BUTTON 9 SIMULATE START BUTTON 10 SIMULATE STOP BUTTON 11 GENERATOR CLOSED AUXILIARY 12 GENERATOR LOAD INHIBIT 13 MAINS CLOSED AUXILIARY 14 MAINS LOAD INHIBIT 15 AUTO RESTORE INHIBIT 16 AUTO START INHIBIT 17 PANEL LOCK 18 SCHEDULED RUNS INHIBITED 19 RESET MAINTENANCE ALARM 20 TRANSFER TO GENERATOR/OPEN MAINS 21 TRANSFER TO MAINS/OPEN GENERATOR 22 REMOTE INHIBIT 23 TEST ON LOAD</i>	
in16	<i>INPUT TIME DELAY</i>	

	Definition of Parameter	User Defined Value
(In2) DIGITAL CONFIGURABLE INPUT (2) page		
in21	<i>DISABLE, USER CONFIGURED OR SELECT FROM LIST</i>	
in22	<i>IF USER CONFIGURED -POLARITY (CLOSE TO ACTIVATE, OPEN TO ACTIVATE)</i>	
in23	<i>IF USER CONFIGURED -INDICATION (STATUS, WARNING NON-LATCHING, WARNING LATCHING, ELECTRICAL TRIP, SHUTDOWN)</i>	
in24	<i>IF USER CONFIGURED -ACTIVATION (ACTIVE FROM STARTING, ACTIVE FROM SAFETY ON, ALWAYS ACTIVE) IF SELECT FROM LIST</i>	
in25	0 REMOTE START 1 AUXILIARY MAINS FAIL 2 SIMULATE LAMP TEST BUTTON 3 SIMULATE HORN RESET BUTTON 4 SIMULATE ALARM RESET BUTTON 5 SIMULATE OFF BUTTON 6 SIMULATE AUTO BUTTON 7 SIMULATE TEST BUTTON 8 SIMULATE MANUAL BUTTON 9 SIMULATE START BUTTON 10 SIMULATE STOP BUTTON 11 GENERATOR CLOSED AUXILIARY 12 GENERATOR LOAD INHIBIT 13 MAINS CLOSED AUXILIARY 14 MAINS LOAD INHIBIT 15 AUTO RESTORE INHIBIT 16 AUTO START INHIBIT 17 PANEL LOCK 18 SCHEDULED RUNS INHIBITED 19 RESET MAINTENANCE ALARM 20 TRANSFER TO GENERATOR/OPEN MAINS 21 TRANSFER TO MAINS/OPEN GENERATOR 22 REMOTE INHIBIT 23 TEST ON LOAD	
in26	<i>INPUT TIME DELAY</i>	

	Definition of Parameter	User Defined Value
(In3) DIGITAL CONFIGURABLE INPUT (3) page		
in31	<i>DISABLE, USER CONFIGURED OR SELECT FROM LIST</i>	
in32	<i>IF USER CONFIGURED -POLARITY (CLOSE TO ACTIVATE, OPEN TO ACTIVATE)</i>	
in33	<i>IF USER CONFIGURED -INDICATION (STATUS, WARNING NON-LATCHING, WARNING LATCHING, ELECTRICAL TRIP, SHUTDOWN)</i>	
in34	<i>IF USER CONFIGURED -ACTIVATION (ACTIVE FROM STARTING, ACTIVE FROM SAFETY ON, ALWAYS ACTIVE)</i>	
in35	<i>IF SELECT FROM LIST 0 REMOTE START 1 AUXILIARY MAINS FAIL 2 SIMULATE LAMP TEST BUTTON 3 SIMULATE HORN RESET BUTTON 4 SIMULATE ALARM RESET BUTTON 5 SIMULATE OFF BUTTON 6 SIMULATE AUTO BUTTON 7 SIMULATE TEST BUTTON 8 SIMULATE MANUAL BUTTON 9 SIMULATE START BUTTON 10 SIMULATE STOP BUTTON 11 GENERATOR CLOSED AUXILIARY 12 GENERATOR LOAD INHIBIT 13 MAINS CLOSED AUXILIARY 14 MAINS LOAD INHIBIT 15 AUTO RESTORE INHIBIT 16 AUTO START INHIBIT 17 PANEL LOCK 18 SCHEDULED RUNS INHIBITED 19 RESET MAINTENANCE ALARM 20 TRANSFER TO GENERATOR/OPEN MAINS 21 TRANSFER TO MAINS/OPEN GENERATOR 22 REMOTE INHIBIT 23 TEST ON LOAD</i>	
in36	<i>INPUT TIME DELAY</i>	

	Definition of Parameter	User Defined Value
(in4) DIGITAL CONFIGURABLE INPUT (4) page		
in41	DISABLE, USER CONFIGURED OR SELECT FROM LIST	
in42	IF USER CONFIGURED -POLARITY (CLOSE TO ACTIVATE, OPEN TO ACTIVATE)	
in43	IF USER CONFIGURED -INDICATION(WARNING NON-LATCHING, WARNING LATCHING, ELECTRICAL TRIP, SHUTDOWN)	
in44	IF USER CONFIGURED -ACTIVATION (ACTIVE FROM STARTING, ACTIVE FROM SAFETY ON, ALWAYS ACTIVE)	
in45	IF SELECT FROM LIST 0 REMOTE START 1 AUXILIARY MAINS FAIL 2 SIMULATE LAMP TEST BUTTON 3 SIMULATE HORN RESET BUTTON 4 SIMULATE ALARM RESET BUTTON 5 SIMULATE OFF BUTTON 6 SIMULATE AUTO BUTTON 7 SIMULATE TEST BUTTON 8 SIMULATE MANUAL BUTTON 9 SIMULATE START BUTTON 10 SIMULATE STOP BUTTON 11 GENERATOR CLOSED AUXILIARY 12 GENERATOR LOAD INHIBIT 13 MAINS CLOSED AUXILIARY 14 MAINS LOAD INHIBIT 15 AUTO RESTORE INHIBIT 16 AUTO START INHIBIT 17 PANEL LOCK 18 SCHEDULED RUNS INHIBITED 19 RESET MAINTENANCE ALARM 20 TRANSFER TO GENERATOR/OPEN MAINS 21 TRANSFER TO MAINS/OPEN GENERATOR 22 REMOTE INHIBIT 23 TEST ON LOAD 24 LOW OIL PRESSURE	
in46	INPUT TIME DELAY	

	Definition of Parameter	User Defined Value
(In5) DIGITAL CONFIGURABLE INPUT (5) page		
in51	<i>DISABLE, USER CONFIGURED OR SELECT FROM LIST</i>	
in52	<i>IF USER CONFIGURED -POLARITY (CLOSE TO ACTIVATE, OPEN TO ACTIVATE)</i>	
in53	<i>IF USER CONFIGURED -INDICATION(WARNING NON-LATCHING, WARNING LATCHING, ELECTRICAL TRIP, SHUTDOWN)</i>	
in54	<i>IF USER CONFIGURED -ACTIVATION (ACTIVE FROM STARTING, ACTIVE FROM SAFETY ON, ALWAYS ACTIVE) IF SELECT FROM LIST</i>	
in55	0 REMOTE START 1 AUXILIARY MAINS FAIL 2 SIMULATE LAMP TEST BUTTON 3 SIMULATE HORN RESET BUTTON 4 SIMULATE ALARM RESET BUTTON 5 SIMULATE OFF BUTTON 6 SIMULATE AUTO BUTTON 7 SIMULATE TEST BUTTON 8 SIMULATE MANUAL BUTTON 9 SIMULATE START BUTTON 10 SIMULATE STOP BUTTON 11 GENERATOR CLOSED AUXILIARY 12 GENERATOR LOAD INHIBIT 13 MAINS CLOSED AUXILIARY 14 MAINS LOAD INHIBIT 15 AUTO RESTORE INHIBIT 16 AUTO START INHIBIT 17 PANEL LOCK 18 SCHEDULED RUNS INHIBITED 19 RESET MAINTENANCE ALARM 20 TRANSFER TO GENERATOR/OPEN MAINS 21 TRANSFER TO MAINS/OPEN GENERATOR 22 REMOTE INHIBIT 23 TEST ON LOAD 24 HIGH TEMPERATURE	
in56	<i>INPUT TIME DELAY</i>	

	Definition of Parameter	User Defined Value
(In6) DIGITAL CONFIGURABLE INPUT (6) page		
in61	<i>DISABLE, USER CONFIGURED OR SELECT FROM LIST</i>	
in62	<i>IF USER CONFIGURED -POLARITY (CLOSE TO ACTIVATE, OPEN TO ACTIVATE)</i>	
in63	<i>IF USER CONFIGURED -INDICATION(WARNING NON-LATCHING, WARNING LATCHING, ELECTRICAL TRIP, SHUTDOWN)</i>	
in64	<i>IF USER CONFIGURED -ACTIVATION (ACTIVE FROM STARTING, ACTIVE FROM SAFETY ON, ALWAYS ACTIVE) IF SELECT FROM LIST</i>	
in65	0 REMOTE START 1 AUXILIARY MAINS FAIL 2 SIMULATE LAMP TEST BUTTON 3 SIMULATE HORN RESET BUTTON 4 SIMULATE ALARM RESET BUTTON 5 SIMULATE OFF BUTTON 6 SIMULATE AUTO BUTTON 7 SIMULATE TEST BUTTON 8 SIMULATE MANUAL BUTTON 9 SIMULATE START BUTTON 10 SIMULATE STOP BUTTON 11 GENERATOR CLOSED AUXILIARY 12 GENERATOR LOAD INHIBIT 13 MAINS CLOSED AUXILIARY 14 MAINS LOAD INHIBIT 15 AUTO RESTORE INHIBIT 16 AUTO START INHIBIT 17 PANEL LOCK 18 SCHEDULED RUNS INHIBITED 19 RESET MAINTENANCE ALARM 20 TRANSFER TO GENERATOR/OPEN MAINS 21 TRANSFER TO MAINS/OPEN GENERATOR 22 REMOTE INHIBIT 23 TEST ON LOAD	
in66	<i>INPUT TIME DELAY</i>	

	Definition of Parameter	User Defined Value
--	-------------------------	--------------------

(out1) CONFIGURABLE OUTPUT (1) page

ou11	POLARITY (NORMALLY OPEN, NORMALLY CLOSED)	
ou12	0 NOT USED 1 AUDIBLE ALARM 2 ALARM RESET 3 AUTO START INHIBIT 4 AUXILIARY MAINS FAILURE 5 BATTERY HIGH VOLTAGE 6 BATTERY LOW VOLTAGE 7 CALLING FOR SCHEDULED RUN 8 CHARGE ALTERNATOR FAILURE 9 COMMON ALARM 10 COMMON ELECTRICAL TRIP ALARM 11 COMMON SHUTDOWN ALARM 12 COMMON WARNING ALARM 13 COOLANT TEMPERATURE HIGH PRE-ALARM 14 COOLANT TEMPERATURE HIGH SHUTDOWN 15 COOLING DOWN TIMER IN PROGRESS 16 DELAYED ALARMS ACTIVE 17 DIGITAL INPUT1 ACTIVE 18 DIGITAL INPUT2 ACTIVE 19 DIGITAL INPUT3 ACTIVE 20 DIGITAL INPUT4 ACTIVE 21 DIGITAL INPUT5 ACTIVE 22 DIGITAL INPUT6 ACTIVE 23 EARTH FAULT 24 ELECTRIC COOLING FAN AFTERSTART 25 ELECTRIC COOLING FAN AFTERSTOP 26 EMERGENCY STOP 27 FAIL TO START ALARM 28 FAIL TO STOP ALARM 29 FUEL RELAY ENERGISED 30 GAS ENGINE IGNITION OUTPUT 31 GENERATOR AT REST 32 GENERATOR AVAILABLE 33 GENERATOR CLOSED AUXILIARY 34 GENERATOR FAILED TO CLOSE 35 GENERATOR FAILED TO OPEN 36 GENERATOR HIGH FREQUENCY PRE-ALARM 37 GENERATOR HIGH FREQUENCY SHUTDOWN 38 GENERATOR HIGH VOLTAGE PRE-ALARM 39 GENERATOR HIGH VOLTAGE SHUTDOWN 40 GENERATOR LOAD INHIBIT 41 GENERATOR LOW FREQUENCY PRE-ALARM 42 GENERATOR LOW FREQUENCY SHUTDOWN 43 GENERATOR LOW VOLTAGE PRE-ALARM 44 GENERATOR LOW VOLTAGE SHUTDOWN 45 GENERATOR MINIMUM ACTIVE POWER 46 GENERATOR STOPPING 47 HORN OUTPUT 48 LAMP TEST 49 LEVEL PREALARM 50 LOSS OF MAGNETIC PICK-UP SPEED SIGNAL 51 MAINTENANCE DUE ALARM 52 MAINS CLOSED AUXILIARY 53 MAINS FAILED TO CLOSE 54 MAINS FAILED TO OPEN 55 MAINS FAILURE 56 MAINS HIGH FREQUENCY 57 MAINS HIGH VOLTAGE 58 MAINS LOAD INHIBIT 59 MAINS LOW FREQUENCY 60 MAINS LOW VOLTAGE 61 NO LOADING COMMAND 62 OIL PRESSURE LOW PRE-ALARM 63 OIL PRESSURE LOW SHUTDOWN 64 OVER CURRENT 65 OVERSPEED PRE-ALARM 66 OVERSPEED SHUTDOWN 67 PANEL LOCK 68 PRE-HEAT(during preheat timer) 69 PRE-HEAT(until end of cranking) 70 PRE-HEAT(until end of warming) 71 PRE-HEAT(until end safety on) 72 REMOTE START PRESENT 73 REMOTE STOP DELAY IN PROGRESS 74 SHORT CIRCUIT 75 START RELAY ENERGISED 76 STARTING ALARM 77 STARTING ALARMS ARMED 78 STOP BUTTON PRESSED 79 SYSTEM IN AUTO MODE 80 SYSTEM IN MANUAL MODE 81 SYSTEM IN OFF MODE 82 SYSTEM IN TEST MODE 83 UNDERSPEED SHUTDOWN 84 UNDERSPEED PRE-ALARM 85 WAITING FOR GENERATOR	

	Definition of Parameter	User Defined Value
--	-------------------------	--------------------

(out2) CONFIGURABLE OUTPUT (2) page

ou21	<i>POLARITY (NORMALLY OPEN, NORMALLY CLOSED)</i>	
ou22	0 NOT USED 1 AUDIBLE ALARM 2 ALARM RESET 3 AUTO START INHIBIT 4 AUXILIARY MAINS FAILURE 5 BATTERY HIGH VOLTAGE 6 BATTERY LOW VOLTAGE 7 CALLING FOR SCHEDULED RUN 8 CHARGE ALTERNATOR FAILURE 9 COMMON ALARM 10 COMMON ELECTRICAL TRIP ALARM 11 COMMON SHUTDOWN ALARM 12 COMMON WARNING ALARM 13 COOLANT TEMPERATURE HIGH PRE-ALARM 14 COOLANT TEMPERATURE HIGH SHUTDOWN 15 COOLING DOWN TIMER IN PROGRESS 16 DELAYED ALARMS ACTIVE 17 DIGITAL INPUT1 ACTIVE 18 DIGITAL INPUT2 ACTIVE 19 DIGITAL INPUT3 ACTIVE 20 DIGITAL INPUT4 ACTIVE 21 DIGITAL INPUT5 ACTIVE 22 DIGITAL INPUT6 ACTIVE 23 EARTH FAULT 24 ELECTRIC COOLING FAN AFTERSTART 25 ELECTRIC COOLING FAN AFTERSTOP 26 EMERGENCY STOP 27 FAIL TO START ALARM 28 FAIL TO STOP ALARM 29 FUEL RELAY ENERGISED 30 GAS ENGINE IGNITION OUTPUT 31 GENERATOR AT REST 32 GENERATOR AVAILABLE 33 GENERATOR CLOSED AUXILIARY 34 GENERATOR FAILED TO CLOSE 35 GENERATOR FAILED TO OPEN 36 GENERATOR HIGH FREQUENCY PRE-ALARM 37 GENERATOR HIGH FREQUENCY SHUTDOWN 38 GENERATOR HIGH VOLTAGE PRE-ALARM 39 GENERATOR HIGH VOLTAGE SHUTDOWN 40 GENERATOR LOAD INHIBIT 41 GENERATOR LOW FREQUENCY PRE-ALARM 42 GENERATOR LOW FREQUENCY SHUTDOWN 43 GENERATOR LOW VOLTAGE PRE-ALARM 44 GENERATOR LOW VOLTAGE SHUTDOWN 45 GENERATOR MINIMUM ACTIVE POWER 46 GENERATOR STOPPING 47 HORN OUTPUT 48 LAMP TEST 49 LEVEL PREALARM 50 LOSS OF MAGNETIC PICK-UP SPEED SIGNAL 51 MAINTENANCE DUE ALARM 52 MAINS CLOSED AUXILIARY 53 MAINS FAILED TO CLOSE 54 MAINS FAILED TO OPEN 55 MAINS FAILURE 56 MAINS HIGH FREQUENCY 57 MAINS HIGH VOLTAGE 58 MAINS LOAD INHIBIT 59 MAINS LOW FREQUENCY 60 MAINS LOW VOLTAGE 61 NO LOADING COMMAND 62 OIL PRESSURE LOW PRE-ALARM 63 OIL PRESSURE LOW SHUTDOWN 64 OVER CURRENT 65 OVERSPEED PRE-ALARM 66 OVERSPEED SHUTDOWN 67 PANEL LOCK 68 PRE-HEAT(during preheat timer) 69 PRE-HEAT(until end of cranking) 70 PRE-HEAT(until end of warming) 71 PRE-HEAT(until end safety on) 72 REMOTE START PRESENT 73 REMOTE STOP DELAY IN PROGRESS 74 SHORT CIRCUIT 75 START RELAY ENERGISED 76 STARTING ALARM 77 STARTING ALARMS ARMED 78 STOP BUTTON PRESSED 79 SYSTEM IN AUTO MODE 80 SYSTEM IN MANUAL MODE 81 SYSTEM IN OFF MODE 82 SYSTEM IN TEST MODE 83 UNDERSPEED SHUTDOWN 84 UNDERSPEED PRE-ALARM 85 WAITING FOR GENERATOR	

	Definition of Parameter	User Defined Value
--	-------------------------	--------------------

(out3) CONFIGURABLE OUTPUT (3) page

ou31	<i>POLARITY (NORMALLY OPEN, NORMALLY CLOSED)</i>	
ou32	0 NOT USED 1 AUDIBLE ALARM 2 ALARM RESET 3 AUTO START INHIBIT 4 AUXILIARY MAINS FAILURE 5 BATTERY HIGH VOLTAGE 6 BATTERY LOW VOLTAGE 7 CALLING FOR SCHEDULED RUN 8 CHARGE ALTERNATOR FAILURE 9 COMMON ALARM 10 COMMON ELECTRICAL TRIP ALARM 11 COMMON SHUTDOWN ALARM 12 COMMON WARNING ALARM 13 COOLANT TEMPERATURE HIGH PRE-ALARM 14 COOLANT TEMPERATURE HIGH SHUTDOWN 15 COOLING DOWN TIMER IN PROGRESS 16 DELAYED ALARMS ACTIVE 17 DIGITAL INPUT1 ACTIVE 18 DIGITAL INPUT2 ACTIVE 19 DIGITAL INPUT3 ACTIVE 20 DIGITAL INPUT4 ACTIVE 21 DIGITAL INPUT5 ACTIVE 22 DIGITAL INPUT6 ACTIVE 23 EARTH FAULT 24 ELECTRIC COOLING FAN AFTERSTART 25 ELECTRIC COOLING FAN AFTERSTOP 26 EMERGENCY STOP 27 FAIL TO START ALARM 28 FAIL TO STOP ALARM 29 FUEL RELAY ENERGISED 30 GAS ENGINE IGNITION OUTPUT 31 GENERATOR AT REST 32 GENERATOR AVAILABLE 33 GENERATOR CLOSED AUXILIARY 34 GENERATOR FAILED TO CLOSE 35 GENERATOR FAILED TO OPEN 36 GENERATOR HIGH FREQUENCY PRE-ALARM 37 GENERATOR HIGH FREQUENCY SHUTDOWN 38 GENERATOR HIGH VOLTAGE PRE-ALARM 39 GENERATOR HIGH VOLTAGE SHUTDOWN 40 GENERATOR LOAD INHIBIT 41 GENERATOR LOW FREQUENCY PRE-ALARM 42 GENERATOR LOW FREQUENCY SHUTDOWN 43 GENERATOR LOW VOLTAGE PRE-ALARM 44 GENERATOR LOW VOLTAGE SHUTDOWN 45 GENERATOR MINIMUM ACTIVE POWER 46 GENERATOR STOPPING 47 HORN OUTPUT 48 LAMP TEST 49 LEVEL PREALARM 50 LOSS OF MAGNETIC PICK-UP SPEED SIGNAL 51 MAINTENANCE DUE ALARM 52 MAINS CLOSED AUXILIARY 53 MAINS FAILED TO CLOSE 54 MAINS FAILED TO OPEN 55 MAINS FAILURE 56 MAINS HIGH FREQUENCY 57 MAINS HIGH VOLTAGE 58 MAINS LOAD INHIBIT 59 MAINS LOW FREQUENCY 60 MAINS LOW VOLTAGE 61 NO LOADING COMMAND 62 OIL PRESSURE LOW PRE-ALARM 63 OIL PRESSURE LOW SHUTDOWN 64 OVER CURRENT 65 OVERSPEED PRE-ALARM 66 OVERSPEED SHUTDOWN 67 PANEL LOCK 68 PRE-HEAT(during preheat timer) 69 PRE-HEAT(until end of cranking) 70 PRE-HEAT(until end of warming) 71 PRE-HEAT(until end safety on) 72 REMOTE START PRESENT 73 REMOTE STOP DELAY IN PROGRESS 74 SHORT CIRCUIT 75 START RELAY ENERGISED 76 STARTING ALARM 77 STARTING ALARMS ARMED 78 STOP BUTTON PRESSED 79 SYSTEM IN AUTO MODE 80 SYSTEM IN MANUAL MODE 81 SYSTEM IN OFF MODE 82 SYSTEM IN TEST MODE 83 UNDERSPEED SHUTDOWN 84 UNDERSPEED PRE-ALARM 85 WAITING FOR GENERATOR	

	Definition of Parameter	User Defined Value
--	-------------------------	--------------------

(out4) CONFIGURABLE OUTPUT (4) page

ou41	<i>POLARITY (NORMALLY OPEN, NORMALLY CLOSED)</i>	
ou42	0 NOT USED 1 AUDIBLE ALARM 2 ALARM RESET 3 AUTO START INHIBIT 4 AUXILIARY MAINS FAILURE 5 BATTERY HIGH VOLTAGE 6 BATTERY LOW VOLTAGE 7 CALLING FOR SCHEDULED RUN 8 CHARGE ALTERNATOR FAILURE 9 COMMON ALARM 10 COMMON ELECTRICAL TRIP ALARM 11 COMMON SHUTDOWN ALARM 12 COMMON WARNING ALARM 13 COOLANT TEMPERATURE HIGH PRE-ALARM 14 COOLANT TEMPERATURE HIGH SHUTDOWN 15 COOLING DOWN TIMER IN PROGRESS 16 DELAYED ALARMS ACTIVE 17 DIGITAL INPUT1 ACTIVE 18 DIGITAL INPUT2 ACTIVE 19 DIGITAL INPUT3 ACTIVE 20 DIGITAL INPUT4 ACTIVE 21 DIGITAL INPUT5 ACTIVE 22 DIGITAL INPUT6 ACTIVE 23 EARTH FAULT 24 ELECTRIC COOLING FAN AFTERSTART 25 ELECTRIC COOLING FAN AFTERSTOP 26 EMERGENCY STOP 27 FAIL TO START ALARM 28 FAIL TO STOP ALARM 29 FUEL RELAY ENERGISED 30 GAS ENGINE IGNITION OUTPUT 31 GENERATOR AT REST 32 GENERATOR AVAILABLE 33 GENERATOR CLOSED AUXILIARY 34 GENERATOR FAILED TO CLOSE 35 GENERATOR FAILED TO OPEN 36 GENERATOR HIGH FREQUENCY PRE-ALARM 37 GENERATOR HIGH FREQUENCY SHUTDOWN 38 GENERATOR HIGH VOLTAGE PRE-ALARM 39 GENERATOR HIGH VOLTAGE SHUTDOWN 40 GENERATOR LOAD INHIBIT 41 GENERATOR LOW FREQUENCY PRE-ALARM 42 GENERATOR LOW FREQUENCY SHUTDOWN 43 GENERATOR LOW VOLTAGE PRE-ALARM 44 GENERATOR LOW VOLTAGE SHUTDOWN 45 GENERATOR MINIMUM ACTIVE POWER 46 GENERATOR STOPPING 47 HORN OUTPUT 48 LAMP TEST 49 LEVEL PREALARM 50 LOSS OF MAGNETIC PICK-UP SPEED SIGNAL 51 MAINTENANCE DUE ALARM 52 MAINS CLOSED AUXILIARY 53 MAINS FAILED TO CLOSE 54 MAINS FAILED TO OPEN 55 MAINS FAILURE 56 MAINS HIGH FREQUENCY 57 MAINS HIGH VOLTAGE 58 MAINS LOAD INHIBIT 59 MAINS LOW FREQUENCY 60 MAINS LOW VOLTAGE 61 NO LOADING COMMAND 62 OIL PRESSURE LOW PRE-ALARM 63 OIL PRESSURE LOW SHUTDOWN 64 OVER CURRENT 65 OVERSPEED PRE-ALARM 66 OVERSPEED SHUTDOWN 67 PANEL LOCK 68 PRE-HEAT(during preheat timer) 69 PRE-HEAT(until end of cranking) 70 PRE-HEAT(until end of warming) 71 PRE-HEAT(until end safety on) 72 REMOTE START PRESENT 73 REMOTE STOP DELAY IN PROGRESS 74 SHORT CIRCUIT 75 START RELAY ENERGISED 76 STARTING ALARM 77 STARTING ALARMS ARMED 78 STOP BUTTON PRESSED 79 SYSTEM IN AUTO MODE 80 SYSTEM IN MANUAL MODE 81 SYSTEM IN OFF MODE 82 SYSTEM IN TEST MODE 83 UNDERSPEED SHUTDOWN 84 UNDERSPEED PRE-ALARM 85 WAITING FOR GENERATOR	

	Definition of Parameter	User Defined Value
--	-------------------------	--------------------

(tr1) START TIMERS page

tr11	MAINS TRANSIENT DELAY	
tr12	REMOTE START DELAY	
tr13	REMOTE STOP DELAY	
tr14	PRE-HEAT	
tr15	PRE-HEAT BYPASS	
tr16	SAFETY ON DELAY	
tr17	HORN DURATION	
tr18	CHARGE EXCITATION TIME	
tr19	COOLING FAN TIME	

(ti2) LOAD/STOPPING TIMERS page

ti21	WARMUP TIMER	
ti22	RETURN DELAY	
ti23	COOLING TIMER	
ti24	GENERATOR FREQUENCY ERROR CONTROL TIME	
ti25	GENERATOR VOLTAGE ERROR CONTROL TIME	
ti26	FAIL TO STOP TIME	

(brEA) BREAKERS page

brSL	HARDWARE BREAKER SELECTION	
GbCC	GEN CLOSE BREAKER CONTACT TYPE	
GbCr	GEN CLOSE BREAKER RELAY TYPE	
GbCt	GEN CLOSE TIMER	
GbOC	GEN OPEN BREAKER CONTACT TYPE	
GbOr	GEN OPEN BREAKER RELAY TYPE	
GbOt	GEN OPEN TIMER	
MbCC	MAIN CLOSE BREAKER CONTACT TYPE	
MbCr	MAIN CLOSE BREAKER RELAY TYPE	
MbCt	MAINS CLOSE TIMER	
MbOC	MAIN OPEN BREAKER CONTACT TYPE	
MbOr	MAIN OPEN BREAKER RELAY TYPE	
MbOt	MAINS OPEN TIMER	
brCP	BREAKER CLOSE PULSE TIME	
brOP	BREAKER OPEN PULSE TIME	
trtm	TRANSFER TIME	

(Enm) ENGINE MAINTENANCE ALARM page

Enm1	RUNNING HOURS INTERVAL	
Enm2	MAINTENANCE DATE INTERVAL	
Enm3	FORCE ENGINE SHUTDOWN WHEN MAINTENANCE IS DUE EN/DIS	
Enm4	ENGINE RUNNING HOUR (LSB)	
Enm5	ENGINE RUNNING HOUR	
Enm6	ENGINE RUNNING HOUR(MSB)	

	Definition of Parameter	User Defined Value
--	-------------------------	--------------------

(Com) COMMUNICATION page		
Co1	SLAVE ADDRESS	
Co2	BAUD RATE	
	0=1200	
	1=2400	
	2=4800	
	3=9600	
Co3	PARITY; 0= NONE, 1= ODD, 2= EVEN	
Co4	STOP BIT	

(EHPG) EXERCISE page		
E1 C	Generator exercise working time on Monday	
E1Hm	Generator exercise work start time on Monday	
E2 C	Generator exercise working time on Tuesday	
E2Hm	Generator exercise work start time on Tuesday	
E3 C	Generator exercise working time on Wednesday	
E3Hm	Generator exercise work start time on Wednesday	
E4 C	Generator exercise working time on Thursday	
E4Hm	Generator exercise work start time on Thursday	
E5 C	Generator exercise working time on Friday	
E5Hm	Generator exercise work start time on Friday	
E6 C	Generator exercise working time on Saturday	
E6Hm	Generator exercise work start time on Saturday	
E7 C	Generator exercise working time on Sunday	
E7Hm	Generator exercise work start time on Sunday	

(DTE) DATE SETUP page		
YEAr	YEAR	
mon	MONTH	
DATE	DATE	
DAY	DAY	
Hour	HOUR	
min	MIN	
SEC	SEC	

(PAS) PASSWORD page		
oPPS	OPERATOR PASSWORD	
tCPS	TECHNICIAN PASSWORD	

Change Date : / /
Change Technician Name :